

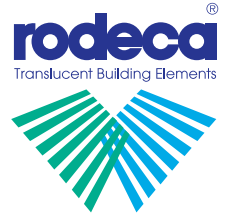

SUMPLASTECNIC  
SUMINISTROS PLÁSTICOS TÉCNICOS



## Technical manual



40



## Translucent Building Elements 40 mm

**Polycarbonate façade construction systems  
for seamless glazing**

PC 2540-10DX | PC 2540-10 | PC 2540-7 |  
PC 2540-6 | PC 2540-4 | PC 2540-4 MC



# General information

## on translucent building elements of Polycarbonate

---

### The raw material

Polycarbonate (PC) is a crystal clear, high impact thermoplastic.

### Advantages

- Temperature resistance between -40 to +115°C, temporarily up to +130 °C
- High impact resistance nearly unchanging within these temperatures
- Good long term performance through UV protection

### UV co-extrusion

With this technique a high concentrated UV protection film is homogeneously melted onto the basis material while production process.

### This offers the following advantages:

- No adhesion problems of UV protection film
- Same temperature behaviour of base and UV material
- No impairment of high impact (like e.g. with coated or painted surfaces)
- Makes small cold bending radiuses possible.
- Better resistance against environmental influences and ageing.
- The thickness of the Coextrusion layer may influence the colouring.

### Outside Performance

Through the coextruded UV-protection film – which is always applied on the outer wall and if desired (surcharge) for some of the products is also available both-sided – our products offer best weather resistance and very good long term performance.

### Warranty

Rodeca offers 10 years warranty (according to written warranty) to its uv-coextruded products regarding to **yellowing index – ageing – hail**

### Light transmission

Customized on project demand Rodeca can produce products with light transmission from almost 0% up to 80% light transmission (depending on material thickness and number of layers). Due to in-house compounding and raw material refinement special requests and colours can be realized. Please inquire project demands which vary from our standards.

### G-Value (Solar gain value, overall energy transmittance)

The overall energy transmittance indicates how much of external solar energy reaches the interior of the room. For optimum passive use of solar energy, the g-value should be as high as possible and as deep as possible for optimum sun protection.

### Up-values and Uf-values (heat transmission coefficient - Up=U-value panel; Uf =U-value frame)

Throughout the multi-walled design of our translucent building elements translucent facades with thermally broken aluminium profiles can be designed very energy efficient.

### UV transmission

UV-radiation is stopped almost to 100% up to 380 Nm because of high UV-stabilization with coextruded UV-protection. The remaining transmission in the area of UV radiation is less than 1%. This property can be very important for UV sensitive goods.



# General information

## on translucent building elements of Polycarbonate

Stand: 02/20

### Ball rebound safety

Ball rebound safety was tested and passed according to DIN 18032 part 3. Please inquire the test report if required.

### Fire resistance

Polycarbonate has a very high ignition temperature of approx. 450 °C and in case of fire the smoke development is very little. Rodeca products are classified according to the European standard DIN EN 13501 and are classified as hardly inflammable. Additionally the fire resistance of our products is classified according to various national standards. Please inquire the test certificates when needed.

### Meltable area

In many fire protection concepts Rodeca panels are considered as melt-surface according to DIN 18230-1 because the softening point of PC is below 300°C.

### Sound insulation

Polycarbonate panels have a sound insulation value up to 22 dB according to DIN EN ISO 10140-2. With a double wall construction a considerably higher value can be achieved. The value refers to the panel only and may differ due to structural conditions.

### Chemical resistance

PC elements possess a very high resistance to chemicals but can be affected through some chemical bounds. Chemical resistance of polycarbonate against other used chemicals has to be checked by customer on site. This is especially important for cooling substances, lubricants, surfactants, sealants, ammonia, etc. A policy on the compatibility of polycarbonate with chemicals can be found i.a. at: <http://www.buerkle.de/en/knowhow/information/chemical-resistance.html>

### Painting

In case that the polycarbonate panels for advertising reasons or similar will be painted or screen printed the compatibility of the painting system needs necessarily be tested from customer before use. The aluminium frame profiles can be powder coated according to the project needs. Additionally Rodeca offers the possibility to deliver TPE gaskets in custom made colours.

### Vinyl wrap

For advertising purposes large scale letters can be glued onto the panels' surface. It is important that the foil and the glue doesn't contain substances which harm and affect polycarbonate. Please clarify before usage with the vinyl wrap supplier or the advertising company if the ingredients/glues of the foil intended to use are compatible with Polycarbonate.

### Cleaning/Maintenance

For durable maintenance of technical and visual properties a regular care, maintenance and cleaning of the translucent building elements is mandatory. The cycles of care, maintenance and cleaning depends on the particular building site and the usage conditions.

Cleaning of translucent building elements: Pure water cleaning systems (osmosis process) have proven themselves. In addition to surface cleaning with soft brushes, if dirt is present in the area of the coupling, the deposited dirt can be cleaned using a high-pressure cleaner in conjunction with the pure water method. Alternatively, water with a small percentage of neutral cleaning agents. No use of glass cleaner, rubbing agents or sharp edged subjects. No alkaline or tensile agents to be used.

### Storage/Transport

Rodeca panels made of polycarbonate have to be protected before sun and wet conditions before installation and must be stored on a plain and even underground. In case of non-observance stock damages may occur. The stacking height of translucent building elements shouldn't exceed 200 cm.

# General information

## on translucent building elements of Polycarbonate

---

### Packaging

The translucent building elements are delivered – depending on the finish – with one-sided or both-sided protective foil. The delivery is carried out – depending on length – from one to four pieces for hand unloading in a recyclable plastic wrapping or on pallet (for forklift unloading). Please unpack briefly before installation to avoid contamination in the hollow chambers. The protective film must be removed after processing and installation. If the Translucent Building Elements are provided with both-side protective film, the protective film on the interior side is applied as transport protection.

### Processing

The Polycarbonate Elements can be smoothly cut with common tools, e.g. pad saw (saw blade with fine indentation) Incidental shavings are to be removed with oil free and water free compressed air.

### Expansion/Shrinking

The expansion coefficient of polycarbonate is 0,065 mm per °C and per m and hence three times as high as the expansion coefficient of aluminium.

Rule of thumb: 3mm per m for 50 °C difference in temperature. Due to temperature differences the length and width of the panel change. The changes in length of the panel need to be considered constructional. Rodeca has considered the length expansion in its system accessories. Thermally caused corrugations can not be excluded completely.

### Sealing

Sealings and sealing tapes need to be polycarbonate compatible and approved for usage from respective producer otherwise damages on the panels are possible.

Silicone: Must be absolutely neutral and solvent free, e. g. Rodeca PC-Silicone 2001. The aluminium profiles need to be protected (according to state of the art technique) against galvanic corrosion and an adequate sealing of building has to be done.

### Condensation

Polycarbonate is a material that is permeable for vapour diffusion so that condensation may occur. This is not a quality defect. Depending from weather/climate this appearance is of temporary nature which is directly linked to temperature and humidity. Condensation doesn't effect the quality of the panels.

### Formation of algae

Algae can just occur in connection of dirt and humidity. Taping of the polycarbonate panels prevents appearance of dirt while stocking and transport.

### Sealing of panel ends

The ends of the panels must be closed before installation - directly after unpacking - with suitable sealing to avoid dust and dirt in the chambers.

With a sealing that is permeable for vapour diffusion (or permeable to water) you run risk that dust, diesel exhaust particulates, gases or other fine particles can diffuse into the panel chambers. For projects with increased particulate matter emission respectively environmental pollution are additionally precautions to be taken. With a joint sealing and additional sealing methods the optical properties of the translucent building materials can be maintained. Every element needs to be sealed singularly. A general recommendation for sealing of panel ends can't be given due to the different installation situations. The complete lack of panel ends sealing cannot be recommended from our experience.



# General information

## on translucent building elements of Polycarbonate

Stand: 02/20

### Aluminium frame profiles

Aluminum frame profiles shall be treated in accordance with the unloading and storage regulations. Mill finish aluminium with oxidative staining is not accepted as reclamation reason. Due to production reasons, the end faces of thermally separated frame profiles are to be trimmed by the customer. Coated or anodised frame profiles can have bores or discolourations of the clamping points of the anodizing process at the lateral ends and are to be shortened if necessary on site. This is not accepted as reclamation reason. Coated profiles can have color deviations to other components in the same color. The chemical resistance of aluminum must be observed. Care and maintenance of aluminum profiles can preserve the optical properties and texture. **Safety** The regional building regulations as well as the general safety regulations for non supporting wall and roof coverings are effective. For a perpetration (according to workplace ordinance (German „Arbeitsstättenrichtlinie“) it is mandatory to use a board of 50 cm width.

### Tolerances according to EN 16153

Panels

Length + 12 mm (up to 3 m) / +0.40 % of panel length (above panel length of 3 m)

Thickness  $\pm$  0.5 mm

Width -2 mm / +6 mm

Weight - 5 %

Concavity length  $\pm$  5 mm per linear meter of panel length

Concavity width  $\pm$  5 mm per linear meter of panel width

Rectangularity < 5 mm per linear meter of panel length

All tolerances are based on room temperature of approx. 20 °C.

Variations in colour saturation and shade between several production batches cannot be precluded (production-related). Variations are always possible and will not be accepted as reason for complaint.

### Disposal of waste/Environmental protection

Rodeca takes leftovers from off-cuts etc. back. Packaging is fully recyclable.

### Joint permeability

Rodeca panels were tested on joint in terms of wind and driving rain. For complete constructions project specific blower door tests have been passed. .

### System accessories

For almost all installation situations Rodeca supplies appropriate and well engineered accessories as well as ventilation flaps and windows in many different versions.

### ETA (European Technical Assessment)

Rodeca panel (LBE) systems are CE marked as specified by the European directive No. 305/2011 and according to ETA 19/0452. The European Technical Assessment - ETA for short - is a European product certification. It is requested in particular for construction products for which there is no harmonized standard. At the same time, ETA authorizes a CE marking. It is mandatory that usability of single certificates is checked in advance from planner /client.

### Environmental Product Declaration (EPD)

To enable qualified building certification, we provide an EPD for our light building elements. The Type III declaration according to ISO 14025 and EN 15804 provides reliable data on the environmental characteristics of the products and thus facilitates the sustainability assessment of buildings. Among other things, it contains important information on the life cycle of the products. This includes, in particular, the environmental key figures required for a certification scheme of buildings. These were calculated for all tongue and groove panels and shown from the cradle to the grave.

# General information

## on translucent building elements of Polycarbonate

---

### **Miscellaneous**

Data subject to technical change.

The aforesaid information and our application technological advice in words, written and through tries, are carried out to best of one's knowledge. This information is non-binding advice even in regards to property rights of third parties. Our advice does not release you from your responsibility to proof self dependently our current advices - especially our safety data sheets and technical information - and to test if our products in regards to applicability for the intended system and use. Application, use and handling of our products – produced from you based on our application technological advice - take place out of our control and therefore you are solely responsible. The sale of our products is carried out according to our current general terms and conditions. Please check before handling if our products are applicable for the intended purpose.



# Content

## Technical manual LBE 40 mm

---

Stand: 02/20

- Content
- Product range
- Technical information panels and load capacities 1.2.1.1 to 1.2.1.15
- Technical information about fastening 1.2.2.0
- Technical information frame systems 1.2.3.0
- Technical information non-thermally broken frame system 1.2.4.0 to 1.2.4.6
- Technical information thermally broken frame system 1.2.5.0 to 1.2.5.6
- Technical information non-thermally broken frame system Eco 1.2.6.0 to 1.2.6.3
- Technical information windowsill systems 1.2.7.0 to 1.2.7.4



# Product Range

## Translucent Building Elements

Standard



### Standard - crystal and opal

PC 2540-10 DX

Up-Value 1.1 W/m<sup>2</sup>K\*\*

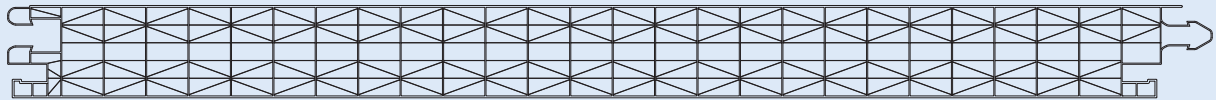

ETA - 19/0452

DuoColor: minimum quantity of 300 m<sup>2</sup>

Building width 495 mm\*

### Standard - crystal and opal

PC 2540-10

Up-Value 1.0 W/m<sup>2</sup>K\*\*

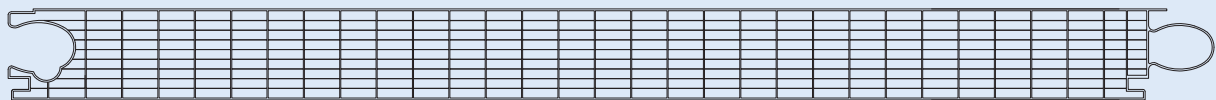

ETA - 19/0452

Color: minimum quantity of 300 m<sup>2</sup>

Building width 500 mm\*

### Standard - crystal and opal

PC 2540-7

Up-Value 1.1 W/m<sup>2</sup>K\*\*

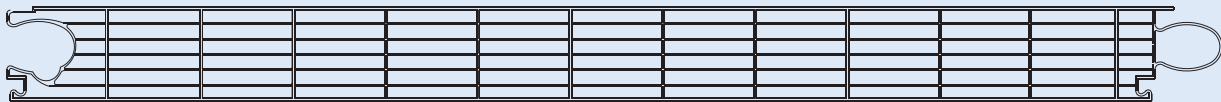

ETA - 19/0452

DecoColor: minimum quantity of 150 m<sup>2</sup>

Building width 500 mm\*

### Standard - crystal and opal

PC 2540-6

Up-Value 1.2 W/m<sup>2</sup>K\*\*



ETA - 19/0452

Color: minimum quantity of 300 m<sup>2</sup>

Building width 500 mm\*

### Standard - crystal and opal

PC 2540-4 MC

Up-Value 1.5 W/m<sup>2</sup>K\*\*

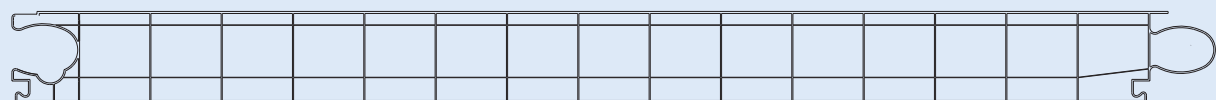

ETA - 19/0452

Building width 500 mm\*



# Product Range

## Translucent Building Elements

Design Series



Stand: 02/20

### DuoColor

PC 2540-10 DX

Up-Value 1.1 W/m<sup>2</sup>K\*\*

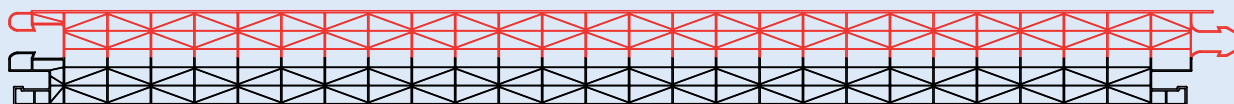

ETA - 19/0452

Building width 495 mm\*

For all colour combinations a minimum quantity of 300 m<sup>2</sup> is necessary.

### DecoColor

PC 2540-7

Up-Value 1.1 W/m<sup>2</sup>K\*\*

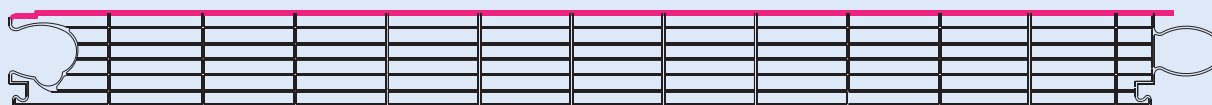

ETA - 19/0452

Building width 500 mm\*

Standard colour combination is Heatbloc S / opal

For all other effect- and colour combinations a minimum quantity of 150 m<sup>2</sup> is necessary.

### BiColor 3D

PC 2540-4

Up-Value 1.4 W/m<sup>2</sup>K\*\*

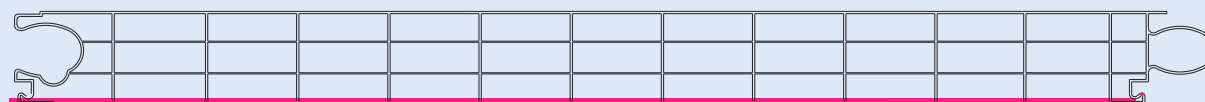

ETA - 19/0452

Building width 500 mm\*

**Standard colour combinations are:**

crystal / RAL 5015, crystal / RAL6029, crystal / RAL5002, crystal / RAL 4006, crystal / RAL3020, crystal / RAL1023, crystal / RAL2009, crystal / RAL 6027 and crystal/opal

For all other effect- or colour combinations a minimum quantity of 150 m<sup>2</sup> is necessary..

Rodeca panels are CE marked as specified by the European directive No. 305/2011 and according to the requirements of EN 16153. Beyond the performance of EN 16153 our products are certified according to several European and national standards. Such as other national fire certifications, proof of joint tightness, certified resistance against ball and puck impact as well as hail resistance etc. corresponding to testing reports. As necessary please contact us for further certifications.

\* Please note our general information regarding production tolerances

\*\* The Up-values depend on the installation situation, for further details please check our technical manuals and the structural-physical values.

Secondary it is mandatory to consider the technical data sheet

INFO@SUMPLASTECNIC.ES

WWW.SUMPLASTECNIC.ES

DISTRIBUIDOR RODECA ESPAÑA



# Product Range

## Translucent Building Elements

Color Series



### Color

PC 2540-6

Up-Value 1.2 W/m<sup>2</sup>K\*\*

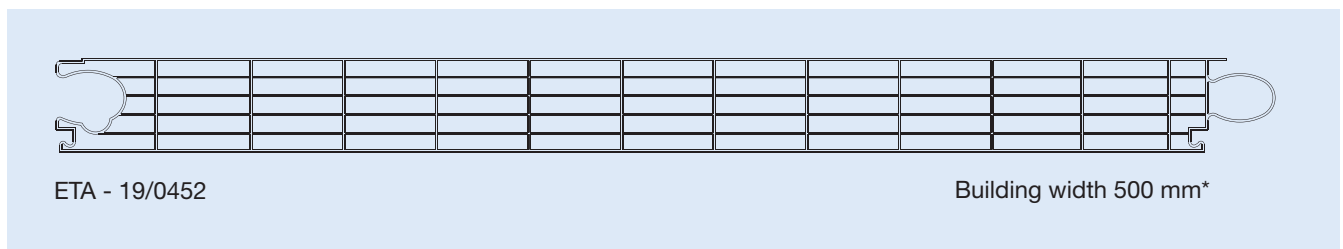

#### Colours:

Pacific blue and petrol deliverable without minimum quantity.

For all other colours a minimum quantity of 300 m<sup>2</sup> is applied. For quantities < 300 m<sup>2</sup> please ask for the minimum quantity surcharges. For colour preferences out of our colour range (30 colour samples according to colour sample box, see below). We kindly ask you to inquire if your preferred colour is already available from stock. If it is necessary we can develop the desired colour.



A customized colour development with colour stripes is possible. For approval of the developed colour you will receive three colour stripes in different colour concentrations. Please inquire the costs in advance. In case that for the sampling additionally panels in desired colour will be needed we are able to help you in decision taking by producing 2 m<sup>2</sup> of panels for 1,000 € only.

\* Please note our general information regarding production tolerances

\*\* The Up-values depend on the installation situation, for further details please check our technical manuals and the structural-physical values.

Secondary it is mandatory to consider the technical datasheets

# Product range

## Rodeca world of colours Translucent Building Elements



Stand: 02/20



### Rodeca colour sample boxes

Since many years our Rodeca colour sample box is a proven and popular resource to showcase colouring of translucent building materials. This box contains 30 different colours and is frequently used to make a preselection for coloured translucent building materials. The new supplementary colour sample box contains a completely new range of 20 colours in frosted and pastel tones.

### Our frosted colours

The special surface of the frosted colours gives the translucent building elements an extremely elegant appearance and the colours are rich and vibrant. At the same time, the frosted colours - in comparison to the standard - are characterized by a lower surface reflection. Frosted colours are available for **PC 2540-7 in DecoColor version, PC 2550-10 and PC 2560-12 in DuoColor.**

### Pastel tones for discreet colour accents

Especially for our Design Series pastel shades are a very good choice. You get delicate colour accents without having to worry too much about the colour impact. The influence of colour to the day light quality is minimized.

### Frosted or pastel tones?

The difference between the two types becomes very clear in below picture. Despite the less intense colours of pastel tone samples the material reflects due to its nature. The matt/frosted colours, on the other hand, have hardly any reflection.

Our well-known sample box with 30 different colours are brilliant and inspired by the colours of a rainbow.

You do not know yet our colour sample boxes? No problem, just contact us and we will send you one.



# 1.2.1.1

## Translucent Building Elements

Product properties

### System PC 2540-10DX

#### Up-Value 1.1 W/m<sup>2</sup>K

in vertical installation situation according to EN ISO 10077-1

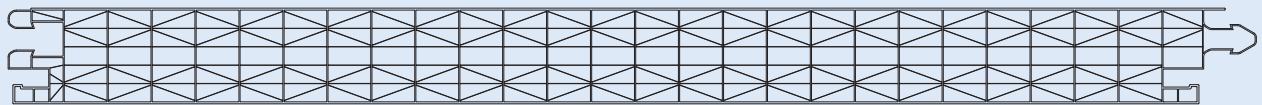

ETA - 19/0452

Building width 495mm

<b>Flammability classification:</b>	fire class B-s1, d0 according to EN 13501
<b>Product properties:</b>	
Building width:	495 mm
Thickness:	40 mm
Weight:	approx. 4.6 kg/m <sup>2</sup>
Number of layers:	10 layers / X structure
Modulus of elasticity:	2,400 N/mm <sup>2</sup>
Coefficient of linear expansion:	0.065 mm/m/°C
UV admission:	< 1 %, wavelengths until 380 nm stopped almost a 100 %
Production tolerances:	s. General information

#### Versions

Standard: Colours crystal and opal

DuoColor:



Two coloured version of the translucent building elements  
For example colour combination:  
Heatbloc S / opal

The DuoColor version can be delivered with a minimum quantity of 300 m<sup>2</sup> without separate surcharges for colour change.

More information about our world of colours in product range.

**Up-values in installation:** 1.1 W/m<sup>2</sup>K vertical / 1.1 W/m<sup>2</sup>K horizontal

#### Light transmission values:

Standard:	Colour: crystal	approx. 46 %
	Colour: opal	approx. 18 %
DuoColor:	Depends from colour combination	

#### Solar gain values g

Standard:	Colour: crystal	approx. 49 %
	Colour: opal	approx. 32 %
DuoColor:	Depends from colour combination	

#### Sound insulation value:

R<sub>w</sub> = 22 db

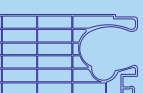

# 1.2.1.2

## Translucent Building Elements

Span width | System 2540-10DX

Stand: 02/20

The below diagrams show the span widths recommendations referring to dimensioning loads. The values are based on ETA-19/0452 and are only valid in conjunction with the Rodeca systems accessories.

Please note that for the structural design of the valid spans to the influencing loads the correspondent national partial safety factors  $\gamma_f$  must be added.

The structural analysis of the span widths must be proven project-related based on ETA-19/0452.

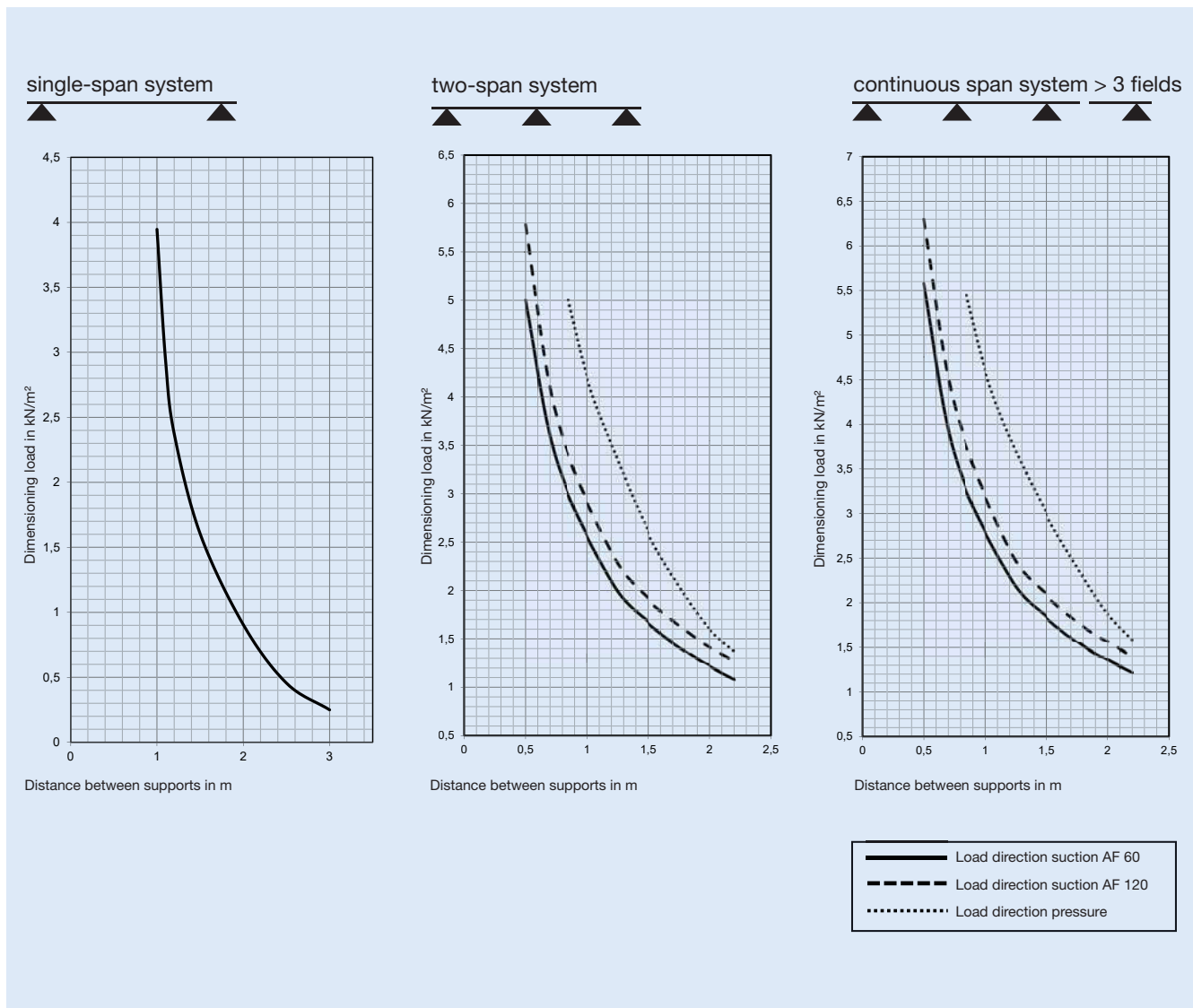

# 1.2.1.3

## Translucent Building Elements

Product properties

### System PC 2540-10

#### Up-Value 1.0 W/m<sup>2</sup>K

in vertical installation situation according to EN ISO 10077-1

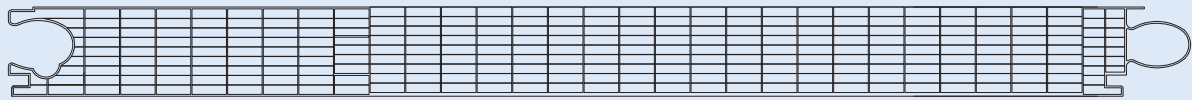

ETA - 19/0452

Building width 500 mm

<b>Flammability classification:</b>	fire class B-s1, d0 according to EN 13501
<b>Product properties:</b>	
Building width:	500 mm
Thickness:	40 mm
Weight:	approx. 4.2 kg/m <sup>2</sup>
Number of layers:	10 layers / 9 chambers
Modulus of elasticity:	2,400 N/mm <sup>2</sup>
Coefficient of linear expansion:	0.065 mm/m/°C
UV admission:	< 1 %, wavelengths until 380 nm stopped almost a 100 %
Production tolerances:	s. General information

<b>Versions:</b>	
Standard:	Colours: crystal and opal

Color



The Color version can be delivered with a minimum quantity of 300 m<sup>2</sup> without separate surcharges for colour change.

More information about our world of colours in product range.

<b>Up-values in installation situation:</b>	1.0 W/m <sup>2</sup> K vertical / 1.0 W/m <sup>2</sup> K horizontal
---	---

<b>Light transmission values:</b>		
Standard:	Colour: crystal	approx. 48 %
	Colour: opal	approx. 25 %

<b>Solar gain values g</b>		
Standard:	Colour: crystal	approx. 50 %
	Colour: opal	approx. 38 %

<b>Sound insulation value:</b>	R <sub>w</sub> = 22 db
--------------------------------	------------------------

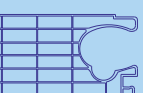

# 1.2.1.4

## Translucent Building Elements

Span widths | System 2540-10

Stand: 02/20

The below diagrams show the span widths recommendations referring to dimensioning loads. The values are based on ETA-19/0452 and are only valid in conjunction with the Rodeca systems accessories.

Please note that for the structural design of the valid spans to the influencing loads the correspondent national partial safety factors  $\gamma_f$  must be added.

The structural analysis of the span widths must be proven project-related based on ETA-19/0452.

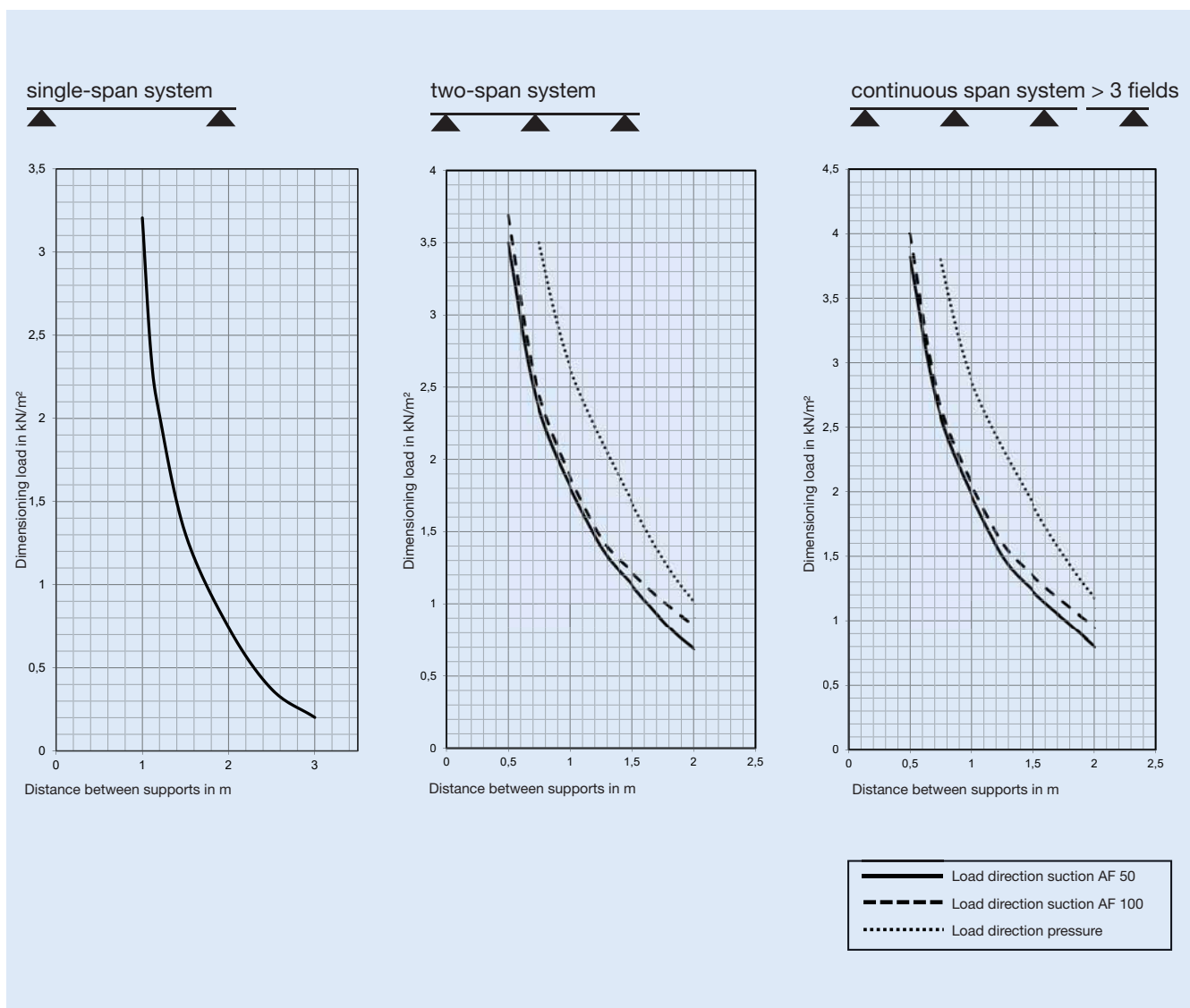

# 1.2.1.5

## Translucent Building Elements

Product properties

### System PC 2540-7

#### Up-Value 1.1 W/m<sup>2</sup>K

in vertical installation situation according to EN ISO 10077-1

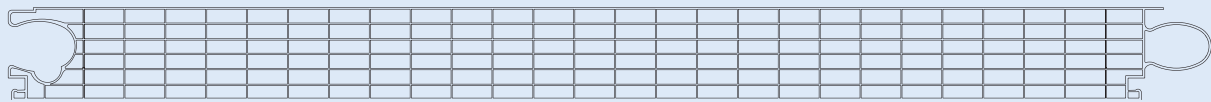

ETA - 19/0452

Building width 500 mm

**Flammability classification:** fire class B-s1, d0 according to EN 13501

**Product properties:**

Building width:	500 mm
Thickness:	40 mm
Weight:	approx. 4.3 kg/m <sup>2</sup>
Number of layers:	7 layers / 6 chambers
Modulus of elasticity:	2,400 N/mm <sup>2</sup>
Coefficient of linear expansion:	0.065 mm/m/°C
UV admission:	< 1 %, wavelengths until 380 nm stopped almost a 100 %
Production tolerances:	s. General information

**Versions:**

Standard: Colours: crystal and opal

DecoColor:

**Two coloured version of the translucent building elements**

For example colour combination:

Heatbloc S / opal  
Titanium grey / opal



**Discover our new mat colours (frosted colours) in DecoColor version!  
Exclusively for our PC 2540-7!**

The DecoColor version can be delivered with a minimum quantity of 150 m<sup>2</sup> without separate surcharges for colour change.

More information about our world of colours in product range.

**Up-values in installation situation:** 1.1 W/m<sup>2</sup>K vertical / 1.2 W/m<sup>2</sup>K horizontal

**Light transmission values:**

Standard:	Colour: crystal	approx. 55 %
	Colour: opal	approx. 25 %

DecoColor:	Depends from colour combination, e. g.	
	Heatbloc S / opal	approx. 22 %
	Opal / crystal	approx. 31 %
	Titanium grey / opal	approx. 7 %

**Solar gain values g:**

Standard:	Colour: crystal	approx. 56 %
	Colour: opal	approx. 39 %

DecoColor:	Depends from colour combination, e. g.	
	Heatbloc S / opal	approx. 31 %
	Opal / crystal	approx. 40 %
	Titanium grey / opal	approx. 21 %



# 1.2.1.6

## Translucent Building Elements

Span width | System 2540-7

Stand: 02/20

The below diagrams show the span widths recommendations referring to dimensioning loads. The values are based on ETA-19/0452 and are only valid in conjunction with the Rodeca systems accessories.

Please note that for the structural design of the valid spans to the influencing loads the correspondent national partial safety factors  $\gamma_f$  must be added.

The structural analysis of the span widths must be proven project-related based on ETA-19/0452.

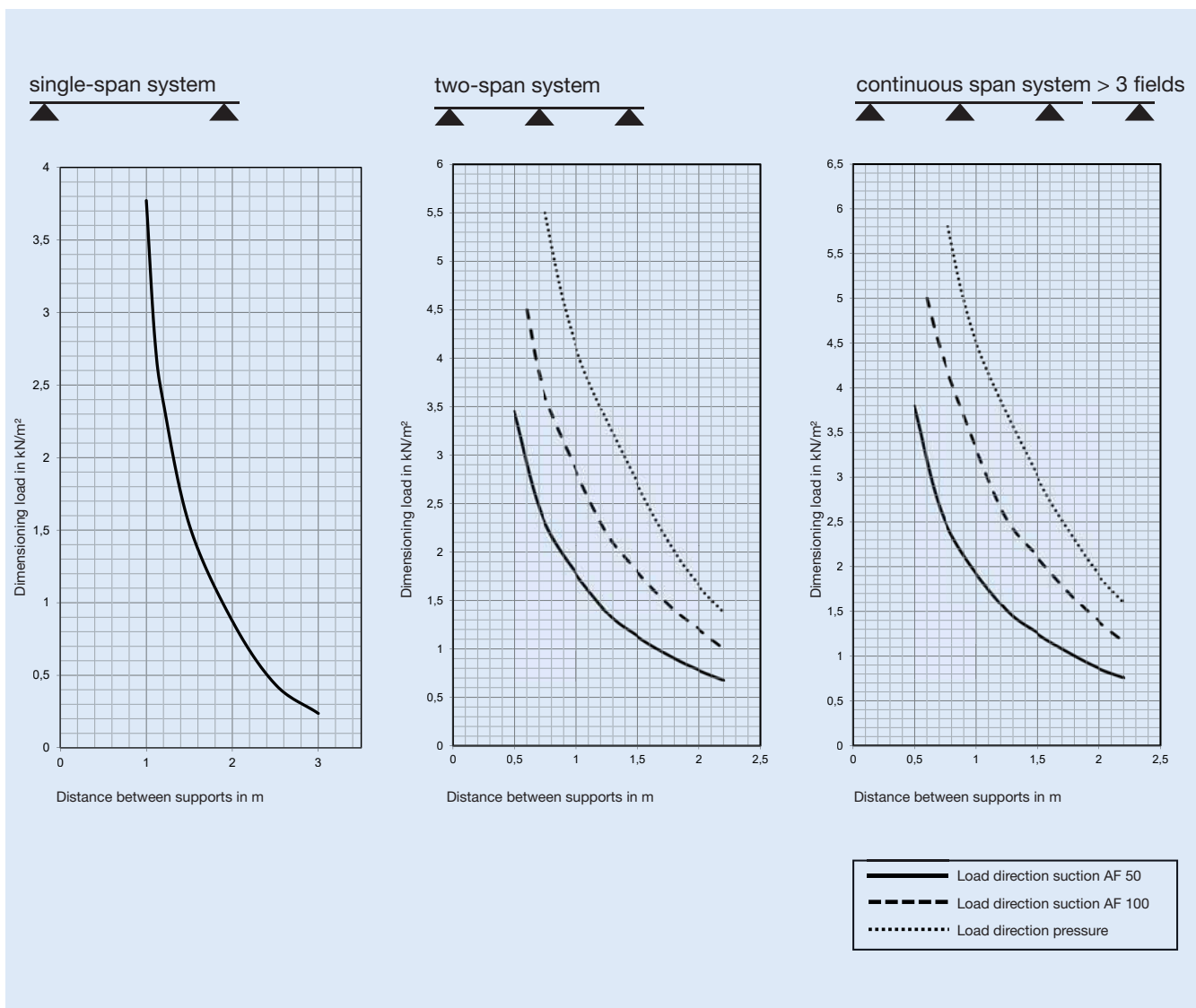

# 1.2.1.7

## Translucent Building Elements

Product properties

### System PC 2540-6

#### Up-Value 1.2 W/m<sup>2</sup>K

in vertical installation situation according to EN ISO 10077-1

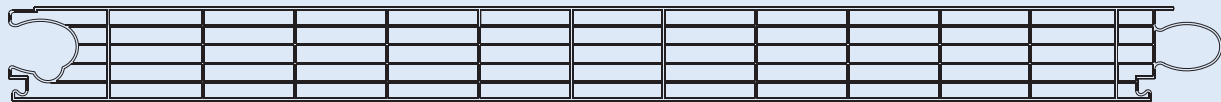

ETA - 19/0452

Building width 500 mm

**Flammability classification:** fire class B-s1, d0 according to EN 13501

**Product properties:**

Building width:	500 mm
Thickness:	40 mm
Weight:	approx. 4.2 kg/m <sup>2</sup>
Number of layers:	6 layers / 5 chambers
Modulus of elasticity:	2,400 N/mm <sup>2</sup>
Coefficient of linear expansion:	0.065 mm/m/°C
UV admission:	< 1 %, wavelengths until 380 nm stopped almost a 100 %
Production tolerances:	s. General information

**Versions:**

Standard: Colours: crystal, opal, crystal clear (without refracting structure), petrol and pacific blue



Color: Available in any solid colour similar to RAL. The Color version can be delivered with a minimum quantity of 300 m<sup>2</sup> without separate surcharges for colour change.

More information about our world of colours in product range.

**Up-values in installation situation** 1.2 W/m<sup>2</sup>K vertical / 1.2 W/m<sup>2</sup>K horizontal

**Light transmission values:**

Standard:	Colour: crystal	approx. 60 %
	Colour: clear	approx. 60 %
	Colour: opal	approx. 28 %
	Colour: pacific blue	approx. 37 %
	Colour: petrol	approx. 50 %

**Solar gain values g**

Standard:	Colour: crystal	approx. 58 %
	Colour: clear	approx. 58 %
	Colour: opal	approx. 41 %
	Colour: pacific blue	approx. 53 %
	Colour: petrol	approx. 52 %

**Sound insulation value:** R<sub>w</sub> = 20 db

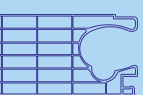

# 1.2.1.8

## Translucent Building Elements

Span width | System 2540-6

Stand: 02/20

The below diagrams show the span widths recommendations referring to dimensioning loads. The values are based on ETA-19/0452 and are only valid in conjunction with the Rodeca systems accessories.

Please note that for the structural design of the valid spans to the influencing loads the correspondent national partial safety factors  $\gamma_f$  must be added.

The structural analysis of the span widths must be proven project-related based on ETA-19/0452.

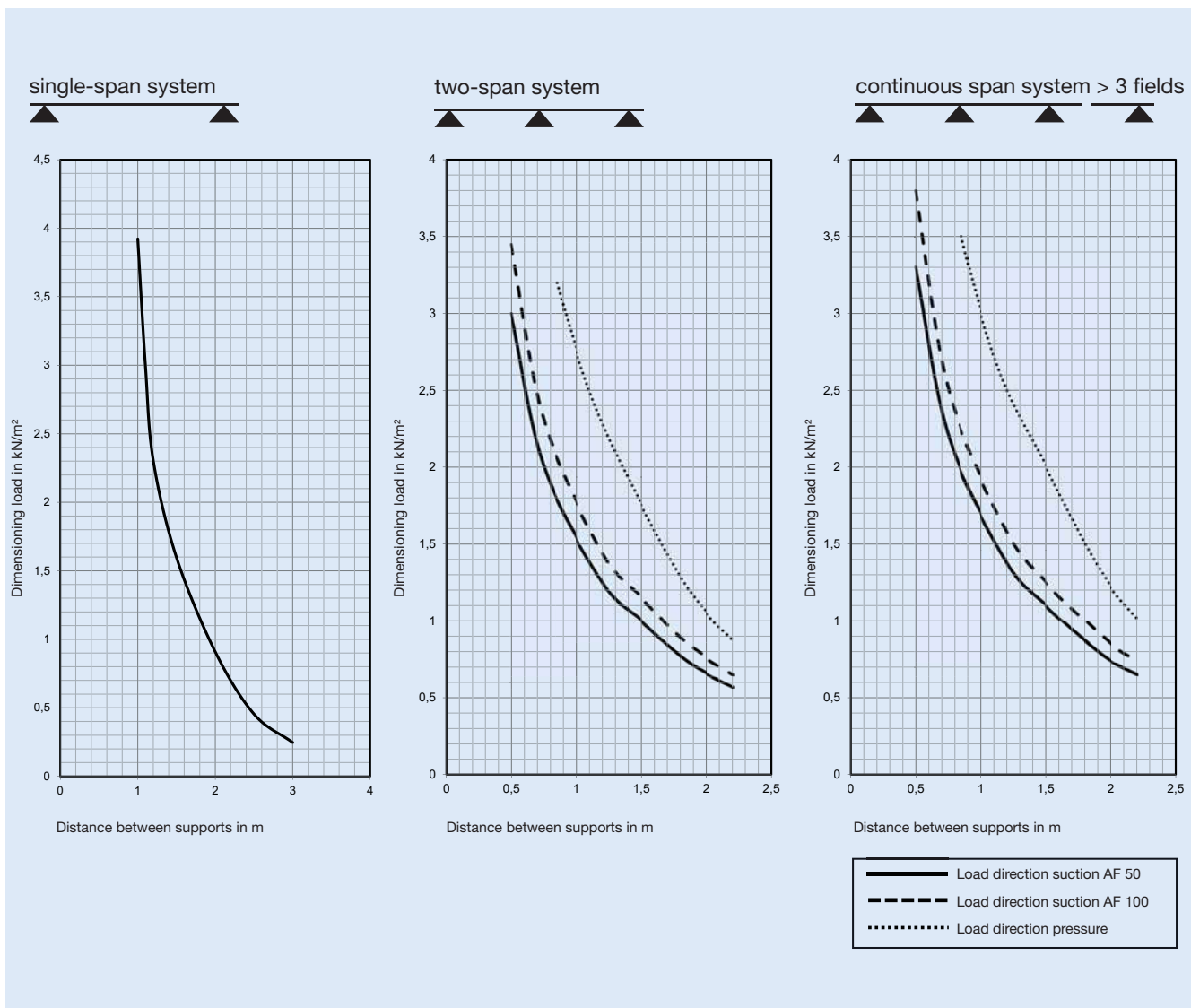

# 1.2.1.9

## Translucent Building Elements

Product properties

### System PC 2540-4

#### Up-Value 1.4 W/m<sup>2</sup>K

in vertical installation situation according to EN ISO 10077-1

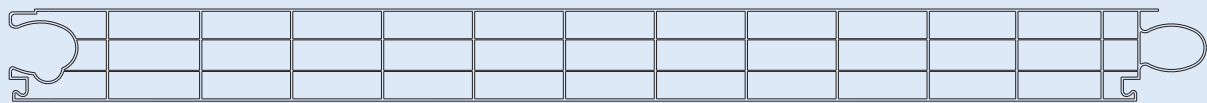

ETA - 19/0452

Building width 500 mm

**Flammability classifications:** fire class B-s1, d0 according to EN 13501

**Product properties:**

Building width: 500 mm  
 Thickness: 40 mm  
 Weight: approx. 4.0 kg/m<sup>2</sup>  
 Number of layers: 4 layers / 3 chambers  
 Modulus of elasticity: 2,400 N/mm<sup>2</sup>  
 Coefficient of linear expansion: 0.065 mm/m/°C  
 UV admission: < 1 %, wavelengths until 380 nm stopped almost a 100 %  
 Production tolerances: s. General information

**Versions:**

Standard: Colours: crystal and opal

BiColor:



**Two coloured versions of the translucent building elements.**

The BiColor version can be delivered with a minimum quantity of 150 m<sup>2</sup> without separate surcharges for the standard colour combinations. Nonstandard combinations beginning from 300 m<sup>2</sup>.

**Standard colours:**

crystal / RAL 1023* - yellow	
crystal / RAL 2009* - orange	crystal / RAL 5015 - pacific blue*
crystal / RAL 3020* - red	crystal / RAL 6027 - petrol*
crystal / RAL 4006* - viola	crystal / RAL 6029 - verde 113*
crystal / RAL 5002* - ultramarine blue	crystal / opal

More information about our world of colours in product range.

**Up-values in installation situation:** 1.4 W/m<sup>2</sup>K vertical / 1.5 W/m<sup>2</sup>K horizontal

**Light transmission values:**

Standard:	Colour: crystal	approx. 63 %
	Colour: opal	approx. 28 %

**Solar gain values**

Standard:	Colour: crystal	approx. 61 %
	Colour: opal	approx. 42 %

**Sound insulation value:** R<sub>w</sub> = 20 db

\*Please note that the indication of RAL color shades for transparent building materials can only be applied in accordance with the RAL card. Please request samples when needed.

# 1.2.1.10

## Translucent Building Elements

Span width | System 2540-4

Stand: 02/20

The below diagrams show the span widths recommendations referring to dimensioning loads. The values are based on ETA-19/0452 and are only valid in conjunction with the Rodeca systems accessories.

Please note that for the structural design of the valid spans to the influencing loads the correspondent national partial safety factors  $\gamma_f$  must be added.

The structural analysis of the span widths must be proven project-related based on ETA-19/0452.

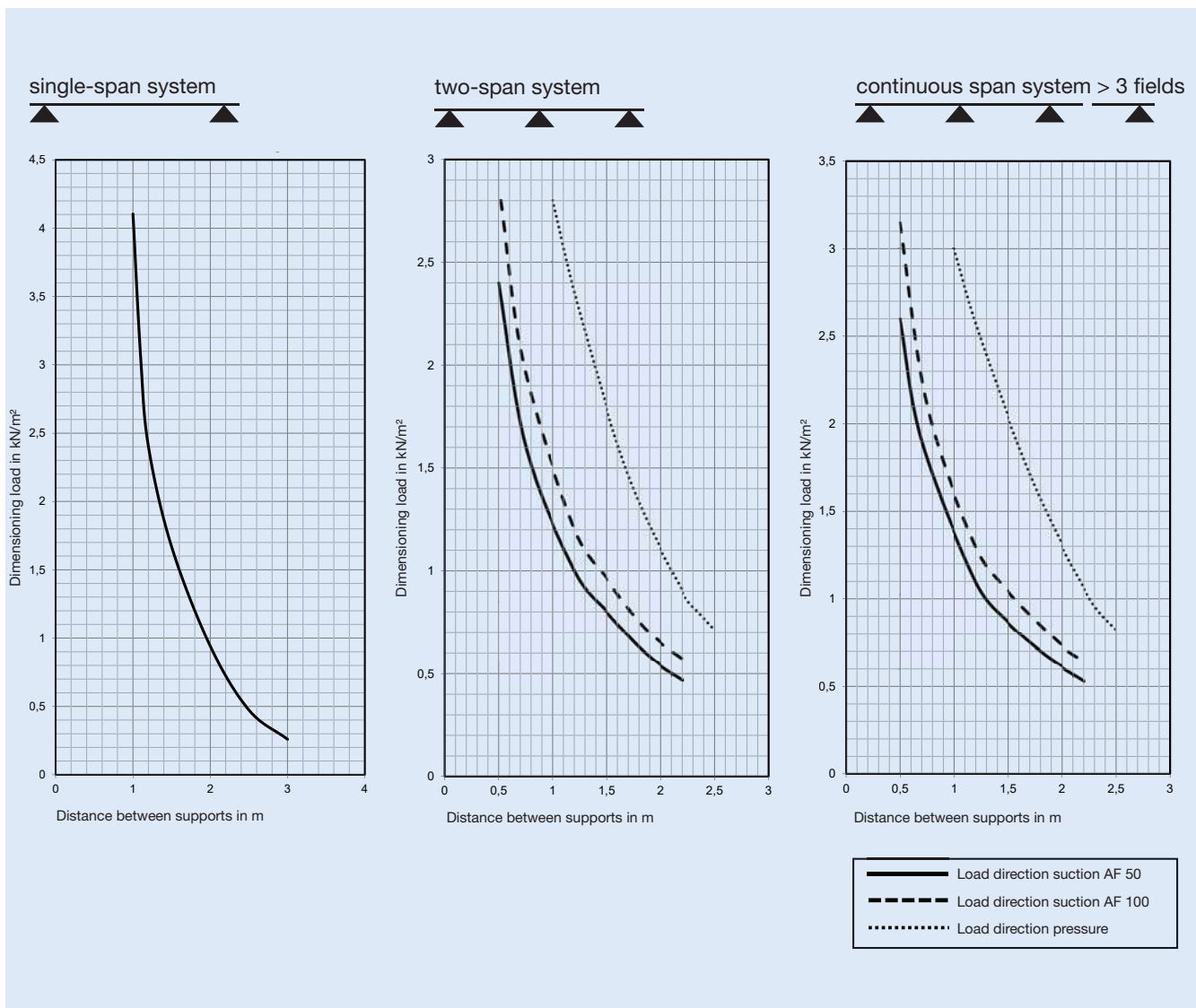

# 1.2.1.11

## Translucent Building Elements

Product properties

### System PC 2540-4 MC

#### Up-Value from 1.5 W/m<sup>2</sup>K

in vertical installation situation according to EN ISO 10077-1

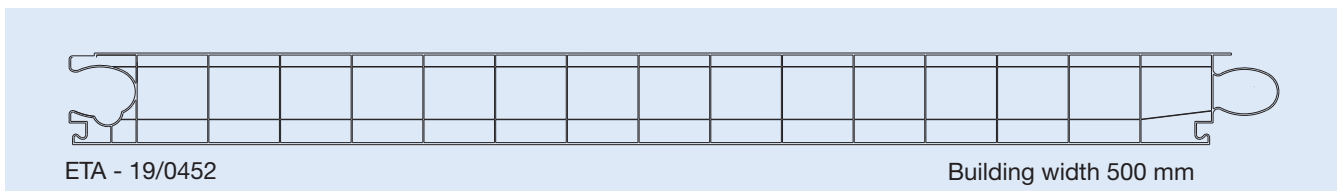

#### PC 2540-4 MC

##### Product properties

Flammability classification:	fire class B-s1, d0 according to EN 13501
Building width:	500 mm
Thickness:	40 mm
Weight:	approx. 4.0 kg/m <sup>2</sup>
Number of layers:	4 layers / 3 chambers
Modulus of elasticity:	2,400 N/mm <sup>2</sup>
Coefficient of linear expansion:	0.065 mm/m/°C
UV admission:	< 1 %, wavelengths until 380 nm stopped almost a 100 %
Production tolerances:	s. General information

##### Versions:

Standard: Colours: crystal and opal

**Up-values in installation situation:** 1.5 W/m<sup>2</sup>K vertical / 1.6 W/m<sup>2</sup>K horizontal

##### Light transmission values :

Standard:	Colour: crystal	approx. 66 %
	Colour: opal	approx. 29 %

##### Solar gain values g

Standard:	Colour: crystal	approx. 60 %
	Colour: opal	approx. 42 %

**Sound insulation value:** R<sub>w</sub> = 20 db

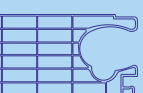

# 1.2.1.12

## Translucent Building Elements

Span width | System 2540-4 MC

Stand: 02/20

The below diagrams show the span widths recommendations referring to dimensioning loads. The values are based on ETA-19/0452 and are only valid in conjunction with the Rodeca systems accessories.

Please note that for the structural design of the valid spans to the influencing loads the correspondent national partial safety factors  $\gamma_f$  must be added.

The structural analysis of the span widths must be proven project-related based on ETA-19/0452.

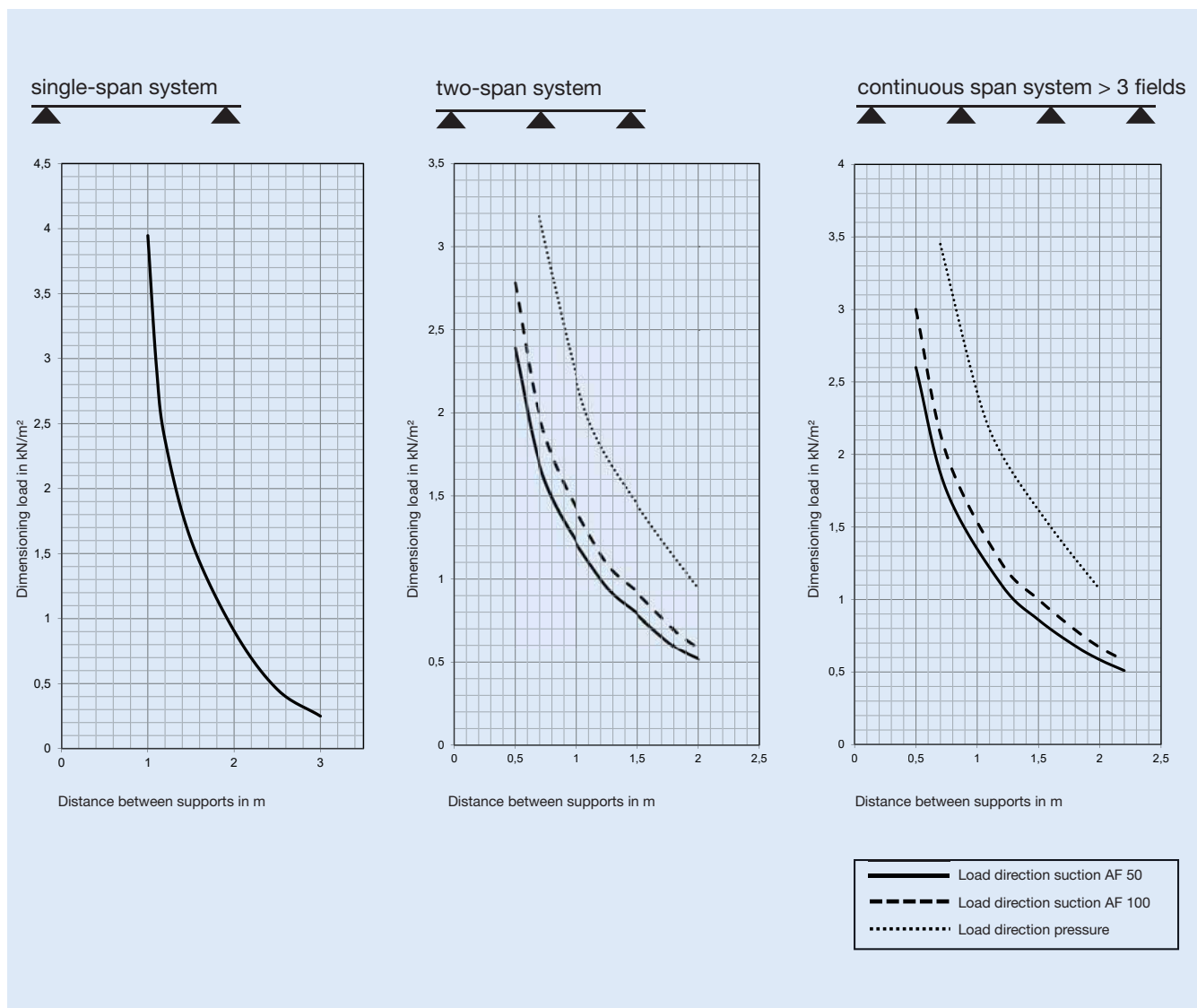

# 1.2.1.13

## Translucent Building Elements

Product version DecoColor 2540-7

### Design Series - DecoColor

**DecoColor means:**

Layer 1 from outside view in colour 1  
Layers 2-7 from outside view in colour 2

Internal production codification BI-A

For the indication of colours always the outside view is taken as basis!

**DecoColor RAL5002/crystal means:**

Layer 1 in colour RAL 5002  
Layers 2-7 in colour crystal

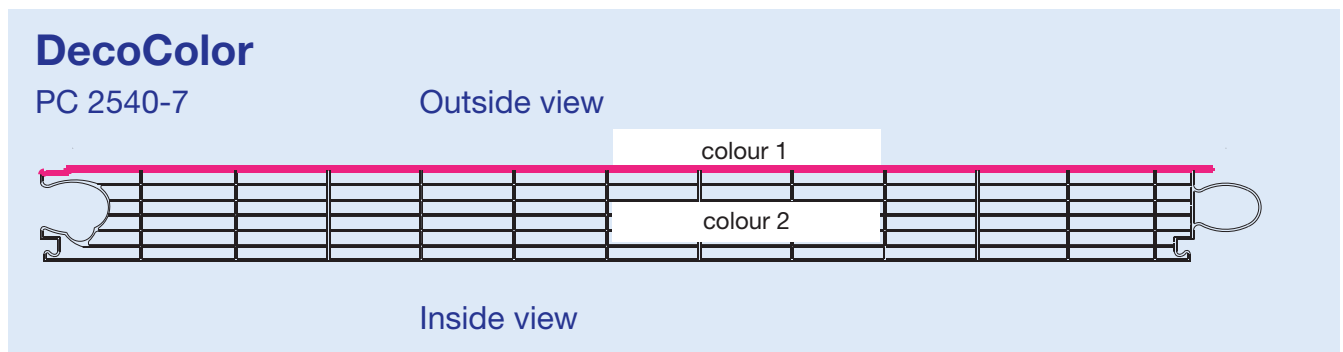

Please use this data sheet as well as basis for your project orders:

**Ordering Information:**

Layer 1 from outside view in colour 1 \_\_\_\_\_

Layers 2-7 from outside view in colour 2 \_\_\_\_\_

For the indication of colours always the outside view is taken as basis!

DecoColor colour 1 \_\_\_\_\_ /colour 2 \_\_\_\_\_

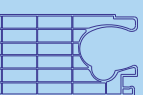



# 1.2.1.14

## Translucent Building Elements

Product version BiColor 2540-4

Stand: 02/20

### Design Series - BiColor

#### BiColor means:

Layers 1-3 from outside view in colour 1  
Layer 4 from outside view in colour 2

Internal production codification BI-I

For the indication of colours always the outside view is taken as basis!

#### BiColor crystal / RAL5002 means:

Layers 1-3 from outside view in crystal  
Layer 4 from outside view in RAL 5002

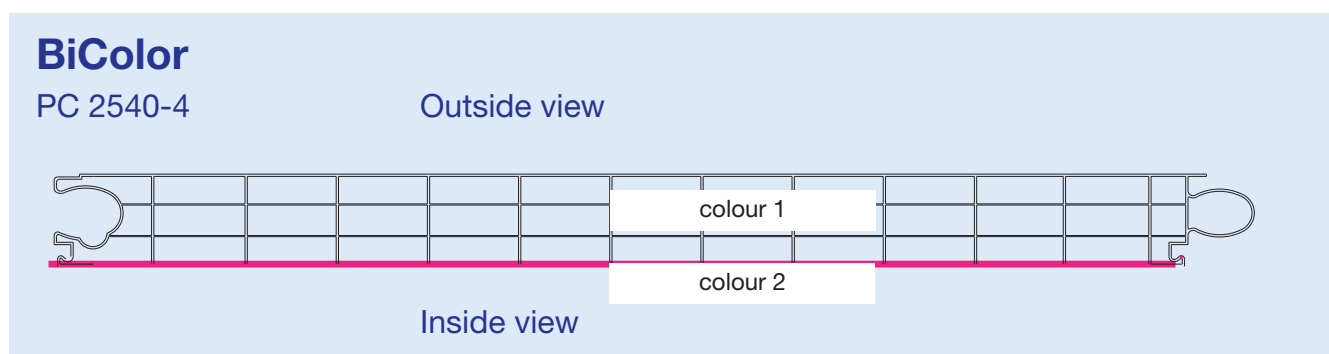

Please use this data sheet as well as basis for your project orders:

#### Ordering information:

Layers 1-3 from outside view in colour 1 \_\_\_\_\_

Layer 4 from outside view in colour 2 \_\_\_\_\_

For the indication of colours always the outside view is taken as basis.

BiColor colour 1 \_\_\_\_\_ /colour 2 \_\_\_\_\_

# 1.2.1.15

## Translucent Building Elements

Product version DuoColor PC 2540-10DX

### Design Series - DuoColor

**DuoColor means:**

Approx. 1/2 of the panel seen from outside view in Colour 1  
Approx. 1/2 of the panel seen from outside view in Colour 2

The separation of the colours is not guaranteed exactly in the middle of the panel but may vary slightly in between the single production charges, due to that differences in transmission can be possible.

For the indication of the colours always the outside view from the panel is taken as basis!

**Example:**

The version DuoColor red / crystal means:  
Approx. Layers 1-5 in colour red  
Approx. Layers 6-10 in colour crystal

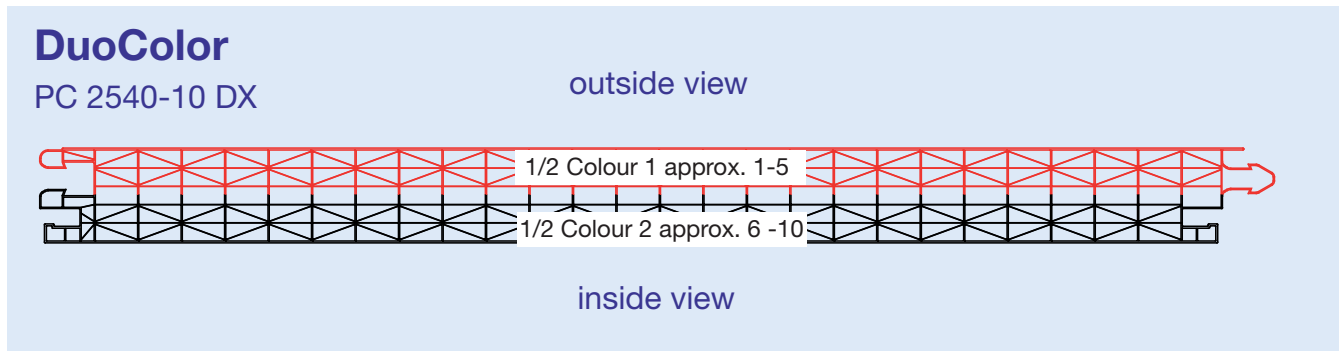

Please note that in your inquiry that the version DuoColor always has the correct sequence of the colour description from outside view to inside view.

In order to avoid mistakes you can attach this data sheet with the description of your desired colour combination to your order.

Please use this data sheet as well as basis for your project orders:

**Ordering information:**

Approx. layers 1 - 5 from outside view in Colour 1    Colour 1 \_\_\_\_\_

Approx. layers 6 -10 from outside view in Colour 2    Colour 2 \_\_\_\_\_

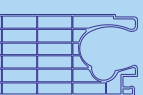

## 1.2.2.0

### Translucent Building Elements

#### Fastener

Stand: 02/20

#### General

The Rodeca flat fasteners are made of extruded aluminium profiles, afterwards cut, pierced and trovalised. We recommend to fix the flat aluminium fasteners with stainless steel screws with screw heads not higher than 5 mm. The fixing materials need to be chosen in type and finish adequately to substructure. The height of substructure should not be smaller than the height of the fastener.

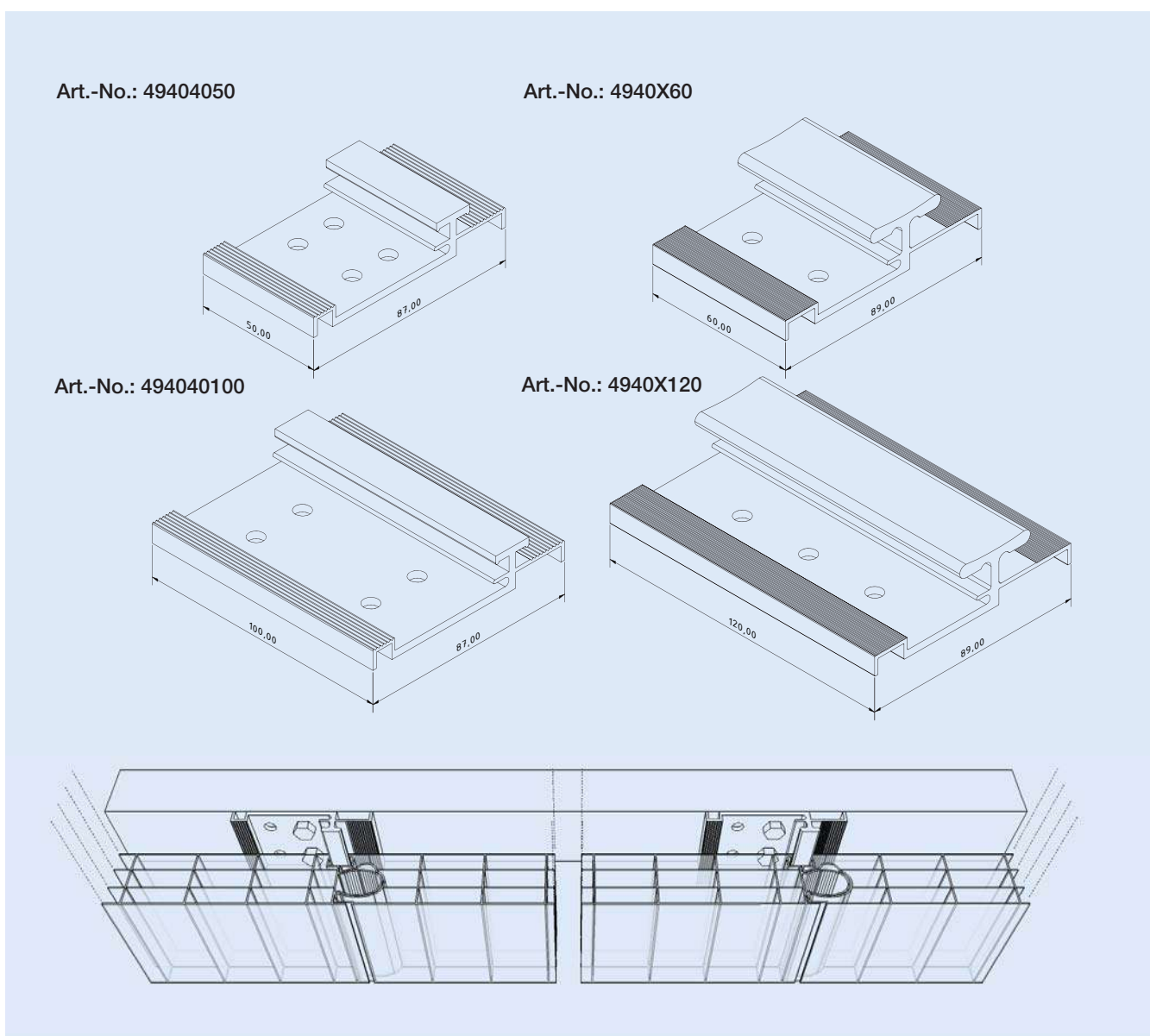

Rodeca flat fastener 49404050 and 494040100 for PC 2540-4 / PC 2540-4 MC / PC 2540-6 / PC 2540-7 / PC 2540-10

Rodeca flat fastener 4940X60 and 4940X120 for PC 2540-10DX



# 1.2.3.0

## Translucent Building Elements

Frame system thermally and non-thermally broken  
General Information

### Mounting situation

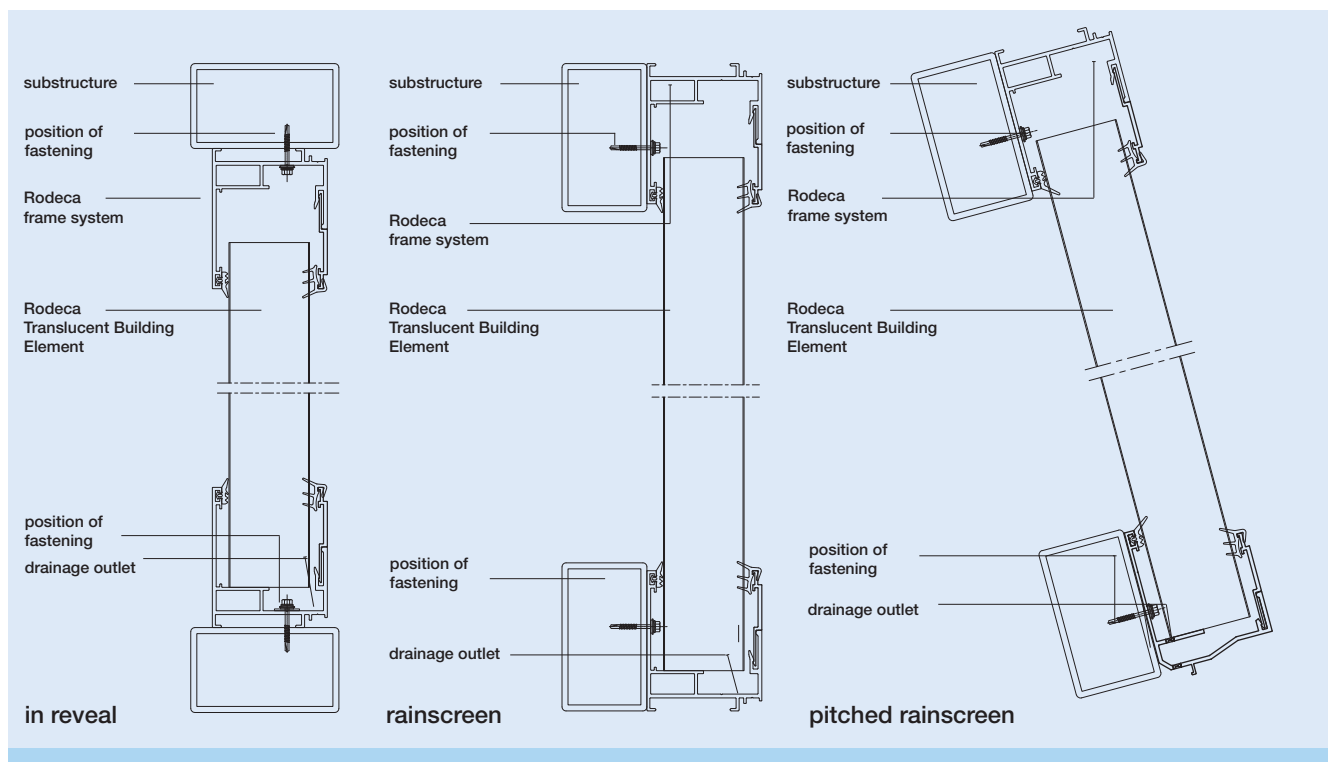

#### General

The examples shown above illustrate the use of Rodeca frame profiles for mounting in reveal, as rainscreen or as a pitched rainscreen construction.

In all cases the sealing between frame sections, frame profile and substructure should be adapted to local conditions. The proof of aluminium profiles, their fixings and the fixing of Rodeca fasteners must be kept in an individual case. Installation of the aluminium profiles with **stainless steel screws** and sealing disc. Dimensions and size according to substructure and extract values of fixing materials. Rodeca assembly instructions must be observed.

Rodeca frame systems are made of extruded Aluminium profiles consisting of Aluminium EN AW-6060, status T 66 according to DIN EN 755-2. The ribs are made of fiber glass reinforced polyamide PA 66 with fiber glass part of 25%. The gaskets are made of TPE.

#### Please note:

The coefficient of linear expansion for Aluminium profiles = 0.023 mm/m°C. Polycarbonate panels = 0.065 mm/m°C.

#### Initial lengths/-units

Aluminium profiles	6.00 m
Front plate	2.0 und 3.0 m
TPE gaskets, grey or black or special colour on request	50 m rolls
Profile connector	10 cm PU* 4pcs.

#### Versions

- Aluminium - mill finish
- Aluminium - anodized E6/C0
- Aluminium - powder coated according to RAL

\*PU = Packing unit

# 1.2.4.0

## Translucent Building Elements

Frame system non-thermally broken  
Top and base framing

Stand: 02/20

### Facade 90° up to 6 m panel length\*

\* at Central European temperature conditions

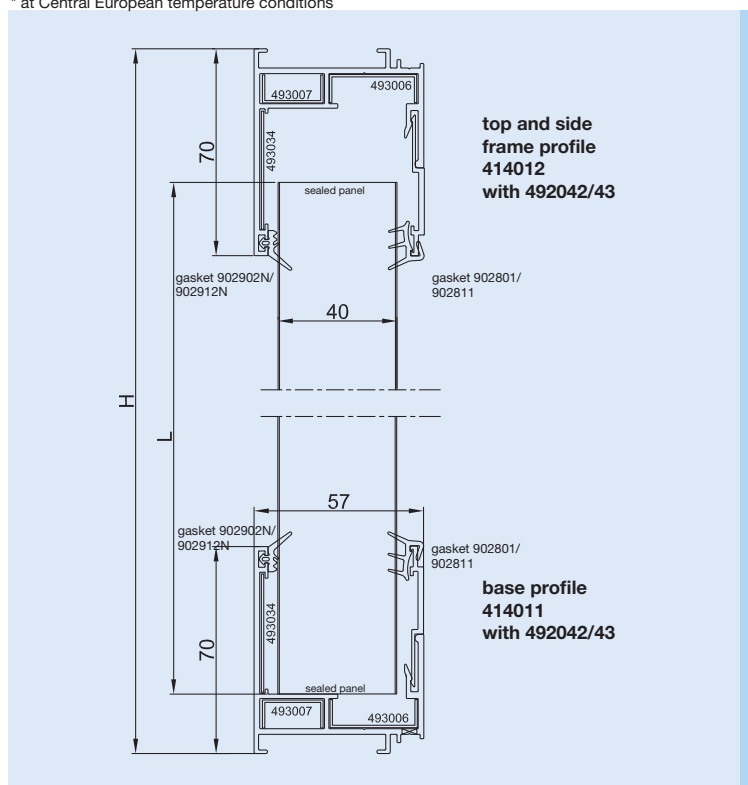

**Top profile 414012**  
**Base profile 414011**

#### Article numbers

**414012** = Top and side frame profile  
493034 = Profile connector for 414012  
493006 = Profile connector for 414012  
493007 = Profile connector for 414012

**414011** = Base profile  
493034 = Profile connector for 414011  
493006 = Profile connector for 414011  
493007 = Profile connector for 414012

**492042** = Front plate in L = 2.0 m  
**492043** = Front plate in L = 3.0 m

**902801** = Outer plug gasket TPE grey  
**902811** = Outer plug gasket TPE black

**902902N** = Inner lip gasket TPE grey  
**902912N** = Inner lip gasket TPE black

Calculation of panel length:  
L in mm = Height H in mm  
less 65 mm at H > 1,500 mm  
less 70 mm at H < 1,500 mm

### Facade 90° up to 12 m panel length\*

\* at Central European temperature conditions

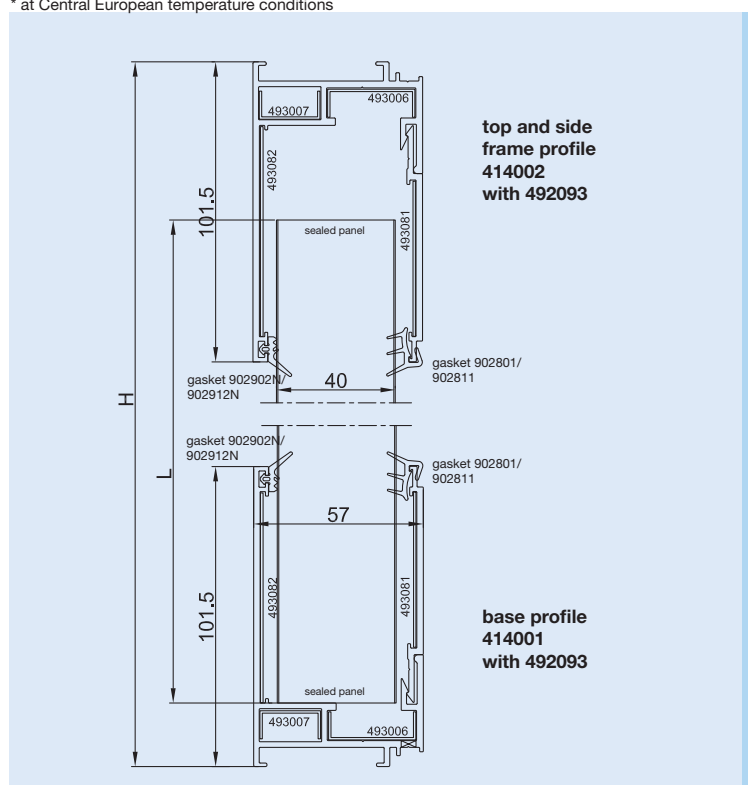

**Top profile 414002**  
**Base profile 414001**

#### Article numbers

**414002** = Top and side frame profile  
493082 = Profile connector for 414002  
493006 = Profile connector for 414002  
493007 = Profile connector for 414002

**414001** = Base profile  
493082 = Profile connector for 414001  
493006 = Profile connector for 414001  
493007 = Profile connector for 414001

**492093** = Front plate in L = 3.0 m  
493081 = Profile connector for 492092/93

**902801** = Outer plug gasket TPE grey  
**902811** = Outer plug gasket TPE black

**902902N** = Inner lip gasket TPE grey  
**902912N** = Inner lip gasket TPE black

Calculation of panel length:  
L in mm = Height H in mm - 75 mm



## 1.2.4.1

### Translucent Building Elements

Frame system non-thermally broken  
Top and base framing

#### Facade 90° up to 6 m panel length\*

\* at Central European temperature conditions

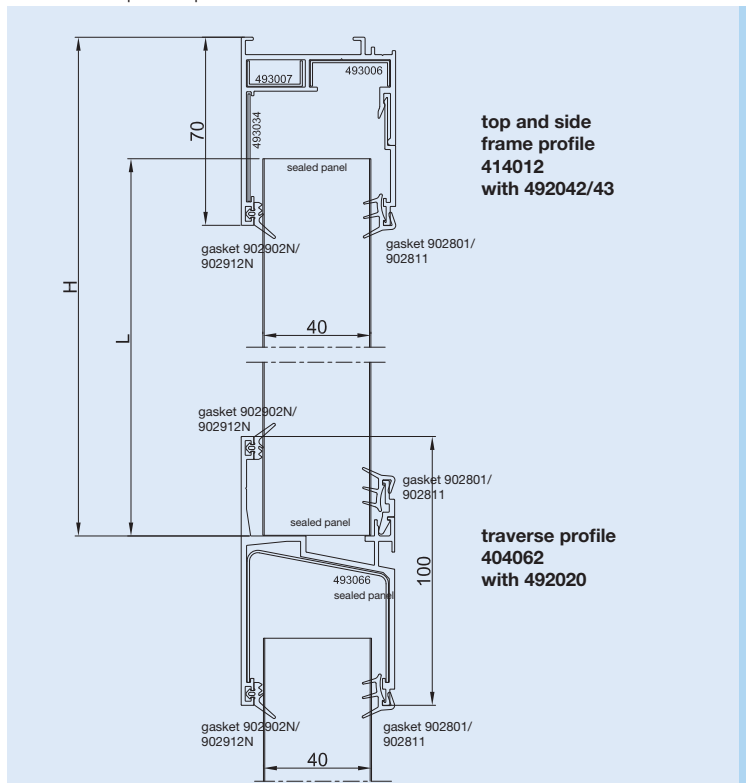

**top and side  
frame profile  
414012  
with 492042/43**

**traverse profile  
404062  
with 492020**

**Top profile 414012**  
**Traverse profile 404062**

#### Article numbers

**414012** = Top and side frame profile  
493034 = Profile connector for 414012  
493006 = Profile connector for 414012  
493007 = Profile connector for 414012

**492042** = Front plate in L = 2.0 m  
**492043** = Front plate in L = 3.0 m

**404062** = Traverse profile  
493066 = Profile connector for 404062

**492020** = Front plate in L = 2.0 m

**902801** = Outer plug gasket TPE grey  
**902811** = Outer plug gasket TPE black

**902902N** = Inner lip gasket TPE grey  
**902912N** = Inner lip gasket TPE black

Calculation of panel length:

$L$  in mm = Height  $H$  in mm - 45 mm

#### Facade 90° up to 12 m panel length\*

\* at Central European temperature conditions

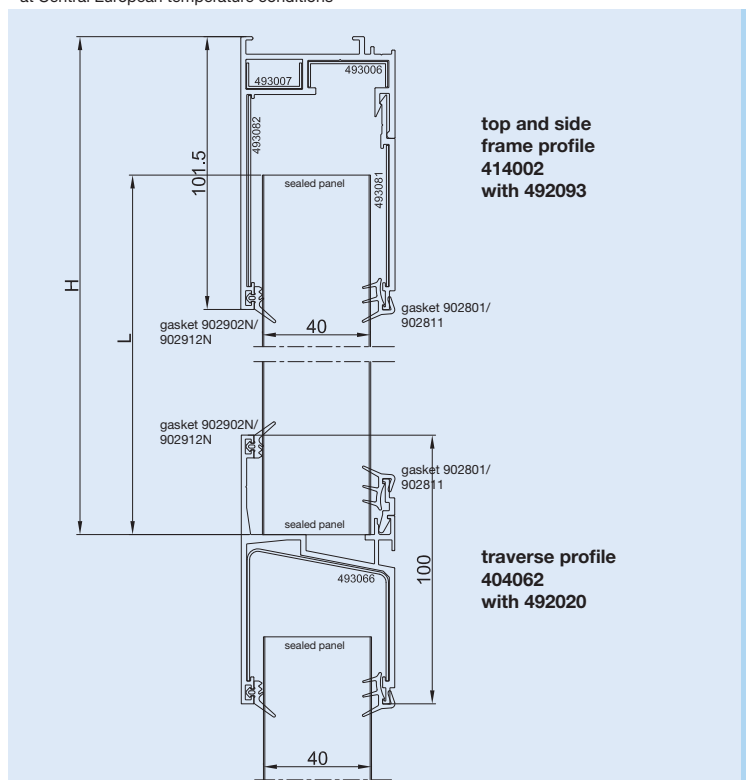

**top and side  
frame profile  
414002  
with 492093**

**traverse profile  
404062  
with 492020**

**Top profile 414002**  
**Traverse profile 404062**

#### Article numbers

**414002** = Top and side frame profile  
493082 = Profile connector for 414002  
493006 = Profile connector for 414002  
493007 = Profile connector for 414002

**492093** = Front plate in L = 3.0 m  
493081 = Profile connector for 492093

**404062** = Traverse profile  
493066 = Profile connector for 404062

**492020** = Front plate in L = 2.0 m

**902801** = Outer plug gasket TPE grey  
**902811** = Outer plug gasket TPE black

**902902N** = Inner lip gasket TPE grey  
**902912N** = Inner lip gasket TPE black

Calculation of panel length:

$L$  in mm = Height  $H$  in mm - 55 mm

## 1.2.4.2

### Translucent Building Elements

Frame system non-thermally broken  
Top and base framing

Stand: 02/20

Facade 90° up to 6 m panel length\*

\* at Central European temperature conditions

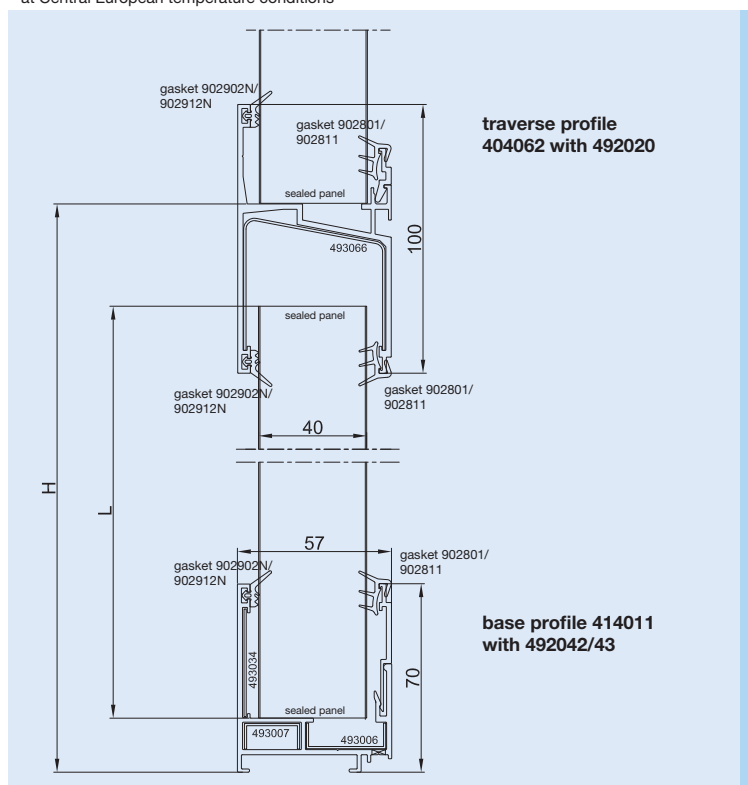

**Traverse profile 404062**  
**Base profile 414011**

#### Article numbers

**404062** = Traverse profile  
493066 = Profile connector for 404062

**492020** = Front plate in L = 2.0 m

**414011** = Base profile  
493034 = Profile connector for 414011  
493006 = Profile connector for 414011  
493007 = Profile connector for 414011

**492042** = Front plate in L = 2.0 m  
**492043** = Front plate in L = 3.0 m

**902801** = Outer plug gasket TPE grey  
**902811** = Outer plug gasket TPE black

**902902N** = Inner lip gasket TPE grey  
**902912N** = Inner lip gasket TPE black

Calculation of panel length:

L in mm = Height H in mm - 60 mm

Facade 90° up to 6 m panel length\*

\* at Central European temperature conditions

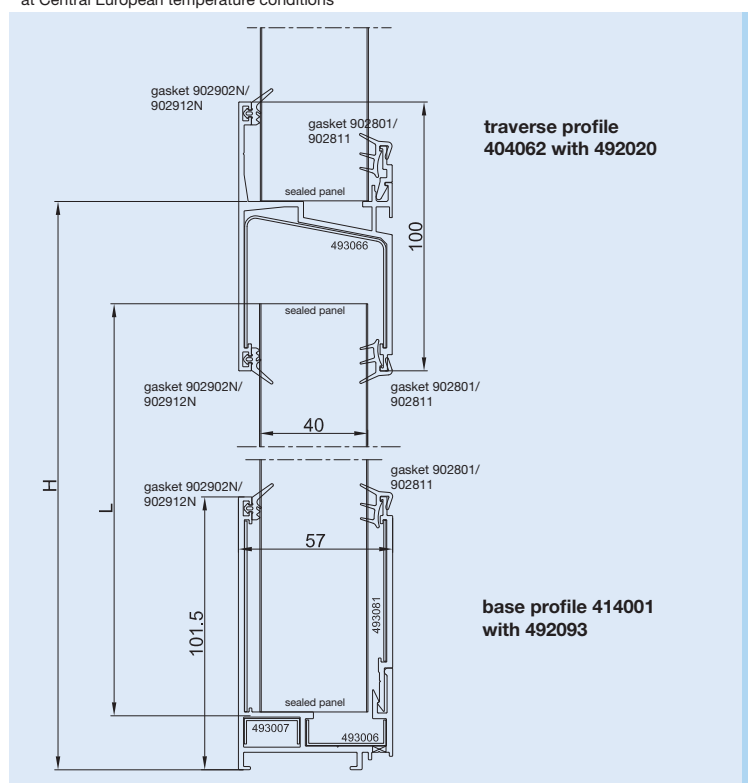

**Traverse profile 404062**  
**Base profile 414001**

#### Article numbers

**404062** = Traverse profile  
493066 = Profile connector for 404062

**492020** = Front plate in L = 2.0 m

**414001** = Base profile  
493082 = Profile connector for 414002  
493006 = Profile connector for 414002  
493007 = Profile connector for 414002

**492093** = Front plate in L = 3.0 m  
493081 = Profile connector for 492093

**902801** = Outer plug gasket TPE grey  
**902811** = Outer plug gasket TPE black

**902902N** = Inner lip gasket TPE grey  
**902912N** = Inner lip gasket TPE black

Calculation of panel length:

L in mm = Height H in mm - 60 mm



## 1.2.4.3

### Translucent Building Elements

Frame system non-thermally broken  
Top and base framing

Facade 90° up to 6 m panel length\*

\* at Central European temperature conditions

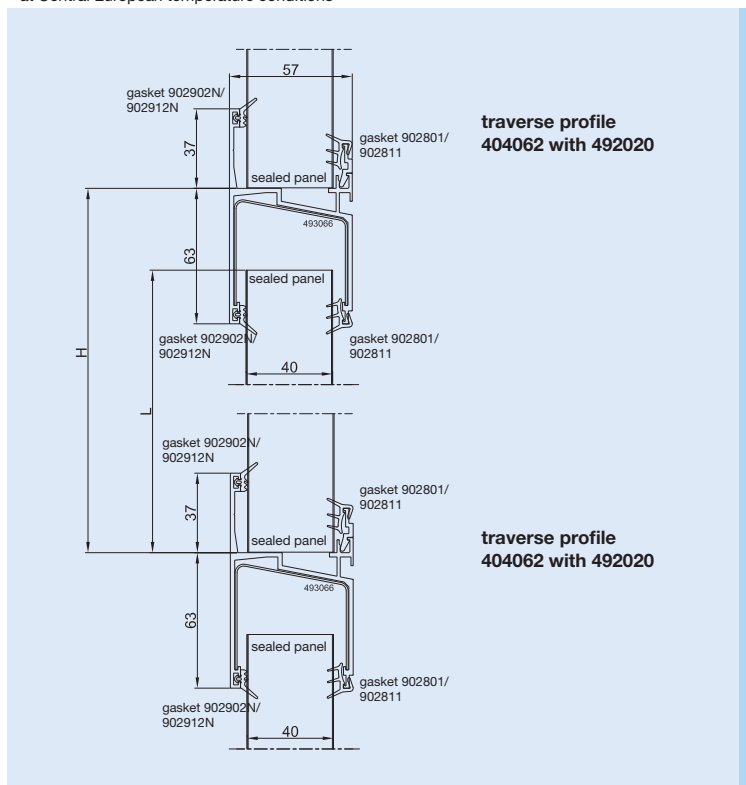

**Traverse profile 404062**  
**Traverse profile 404062**

#### Article numbers

**404062** = Traverse profile  
493066 = Profile connector for 404062

**492020** = Front plate in L = 2.0 m

**902801** = Outer plug gasket TPE grey  
**902811** = Outer plug gasket TPE black

**902902N** = Inner lip gasket TPE grey  
**902912N** = Inner lip gasket TPE black

Calculation of panel length:

$L \text{ in mm} = \text{Height } H \text{ in mm} - 30 \text{ mm}$

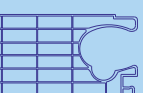



## 1.2.4.4

### Translucent Building Elements

Frame system non-thermally broken  
Top and base framing

Stand: 02/20

#### Pitched installation >15° up to 12 m panel length\*

\* at Central European temperature conditions

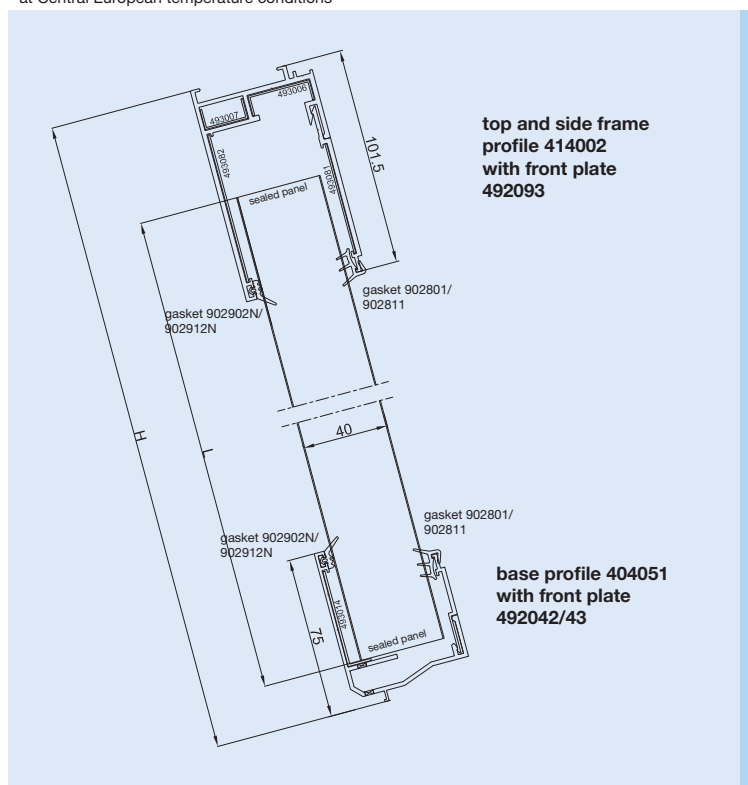

**Top profile 414002**  
**Base profile 404051**

#### Article numbers

**414002** = Top and side frame profile  
493082 = Profile connector for 414002  
493006 = Profile connector for 414002  
493007 = Profile connector for 414002

**492093** = Front plate in L = 3.0 m  
493081 = Profile connector for 492093

**404051** = Base profile  
493014 = Profile connector for 404051

**492042** = Front plate in L = 2.0 m  
**492043** = Front plate in L = 3.0 m

**902801** = Outer plug gasket TPE grey  
**902811** = Outer plug gasket TPE black

**902902N** = Inner lip gasket TPE grey  
**902912N** = Inner lip gasket TPE black

Calculation of panel length:

L in mm = Height H in mm - 75 mm

#### Pitched installation >15° up to 6 m panel length\*

\* at Central European temperature conditions

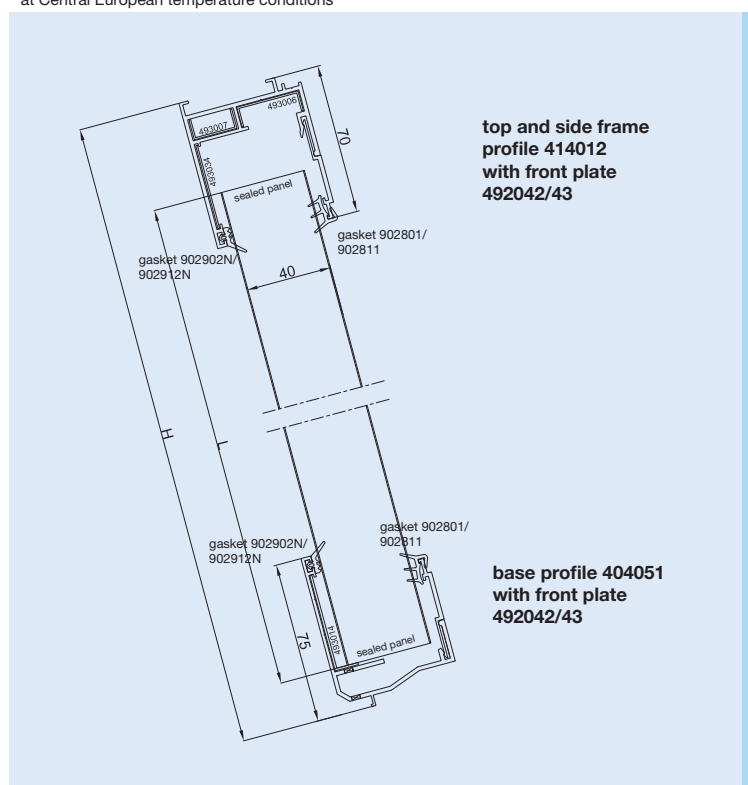

**Top profile 414012**  
**Base profile 404051**

#### Article numbers

**414012** = Top and side frame profile

493034 = Profile connector for 414012  
493006 = Profile connector for 414012  
493007 = Profile connector for 414012

**492042** = Front plate in L = 2.0 m  
**492043** = Front plate in L = 3.0 m

**404051** = Base profile  
493014 = Profile connector for 404051

**492042** = Front plate in L = 2.0 m  
**492043** = Front plate in L = 3.0 m

**902801** = Outer plug gasket TPE grey  
**902811** = Outer plug gasket TPE black

**902902N** = Inner lip gasket TPE grey  
**902912N** = Inner lip gasket TPE black

Calculation of panel length:

L in mm = Height H in mm - 65 mm



## 1.2.4.5

### Translucent Building Elements

Frame system non-thermally broken  
Corner connection

#### 90° corner connection 414005

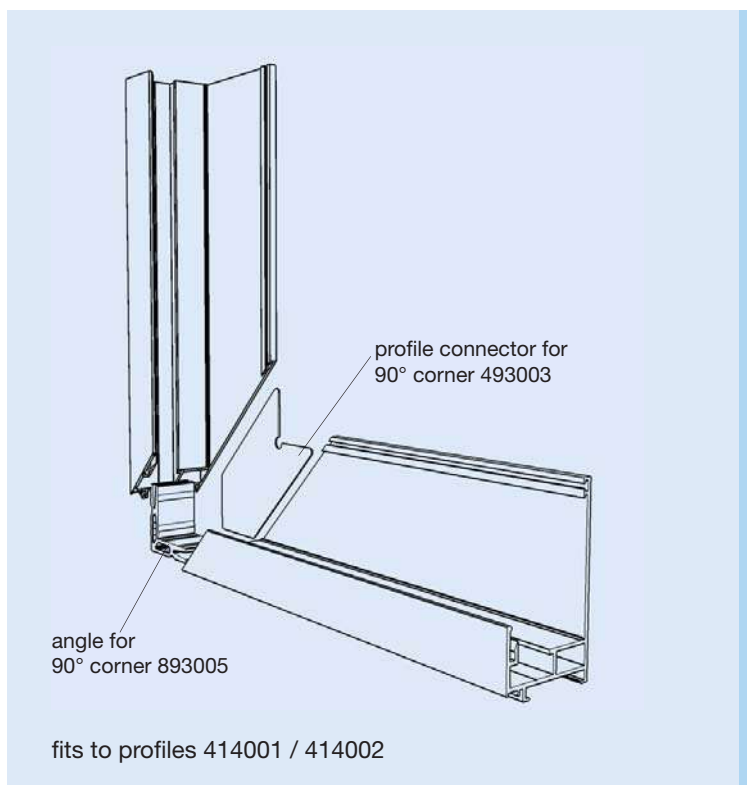

#### General

90° corner connections of the profiles 414002 and 414012 are available as prefabricated components.

The corner connections are made of 0.55m long frame profiles, incl. front plates. The connections are sealed with profile connectors and sealant and thus save installation time and effort.

#### Initial lengths/-units

Prefabricated corner profile incl. front plates and profile connectors	1 pc. PU*
Length 0.55 m	4 pcs. PU*
Profile connector 493003	4 pcs. PU*
Angle for 90° corner 893005	50 m rolls
TPE gaskets, grey or black or special colour on request	10 cm

\*PU = Packing unit

#### 90° corner connection 414015

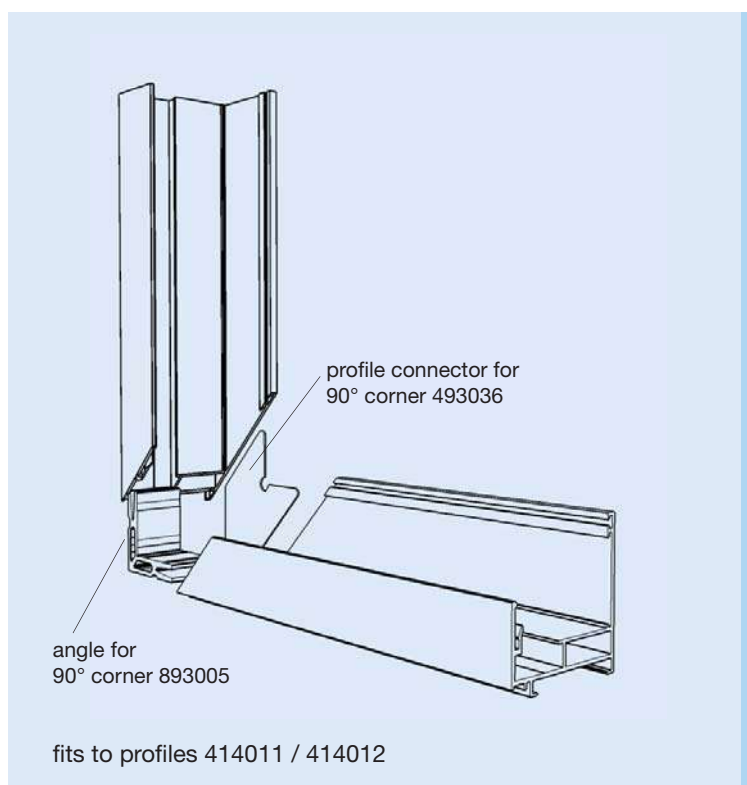

#### Article numbers

**414005** = 90° corner connection prefabricated  
incl. profile connectors and front plate,  
fits to profile 414001 & 414002

493003 = profile connector for a 90° corner  
of profile 414001/02

893005 = angle for a 90° corner of profile 414001/02

**414015** = 90° corner connection prefabricated  
incl. profile connectors and front plate,  
fits to profile 414011 & 414012

493036 = profile connector for a 90° corner  
of profile 414011/12

893005 = angle for a 90° corner of profile 414001/02

#### Versions

Aluminium - mill finish

Aluminium - anodized E6/C0

Aluminium - powder coated according to RAL

## 1.2.4.6

### Translucent Building Elements

Frame system non-thermally broken  
Lateral framing

Stand: 02/20

#### Side connections

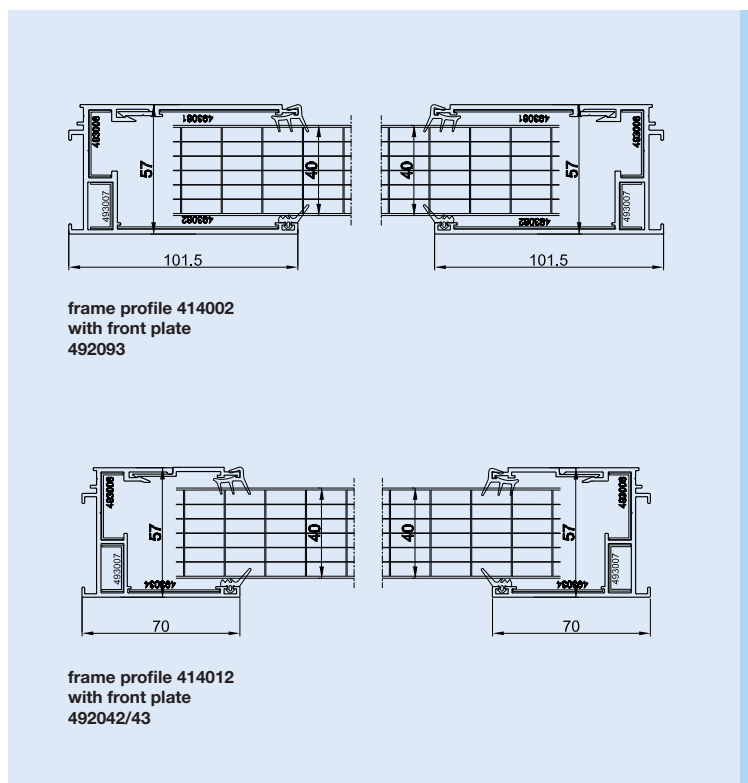

#### Side connection with frame profiles

##### Article numbers

**414002** = Top and side frame profile  
**493082** = Profile connector for 414002  
**493006** = Profile connector for 414002  
**493007** = Profile connector for 414002

**492093** = Front plate in L = 3.0 m  
**493081** = Profile connector for 492093

**414012** = Top and side frame profile  
**493034** = Profile connector for 414012  
**493006** = Profile connector for 414012  
**493007** = Profile connector for 414012

**492042** = Front plate in L = 2.0 m  
**492043** = Front plate in L = 3.0 m

**902801** = Outer plug gasket TPE grey  
**902811** = Outer plug gasket TPE black

**902902N** = Inner lip gasket TPE grey  
**902912N** = Inner lip gasket TPE black

#### Side connection 90° corner

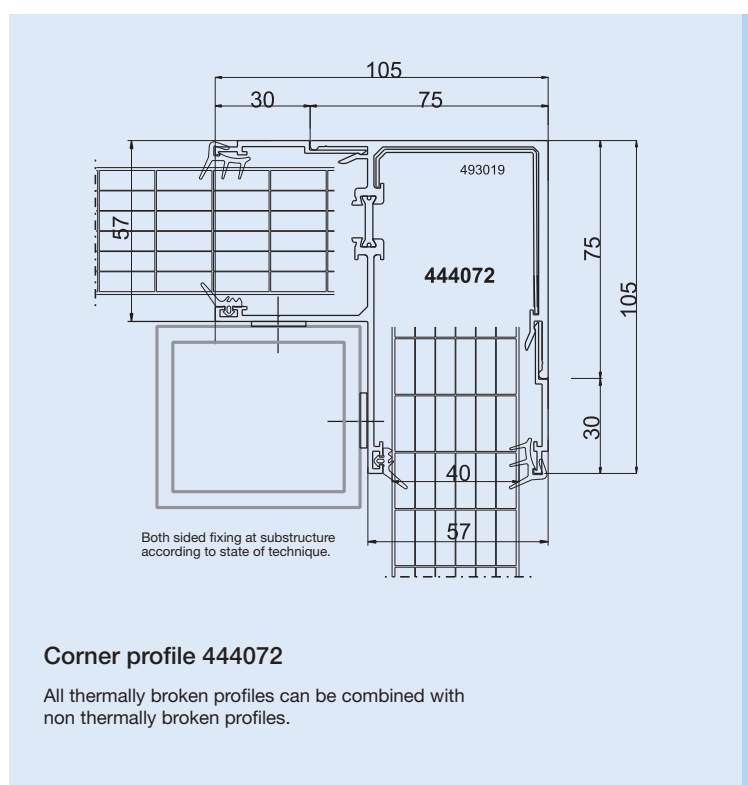

#### Side connection 90° corner with profile 444072

##### Article numbers

**444072** = Corner profile  
**493019** = Profile connector for 444072

**492042** = Front plate in L = 2.0 m  
**492043** = Front plate in L = 3.0 m

**902801** = Outer plug gasket TPE grey  
**902811** = Outer plug gasket TPE black

**902902N** = Inner lip gasket TPE grey  
**902912N** = Inner lip gasket TPE black



# 1.2.5.0

## Translucent Building Elements

Frame system thermally broken  
Top and base framing

### Facade 90° up to 6 m panel length\*

\* at Central European temperature conditions

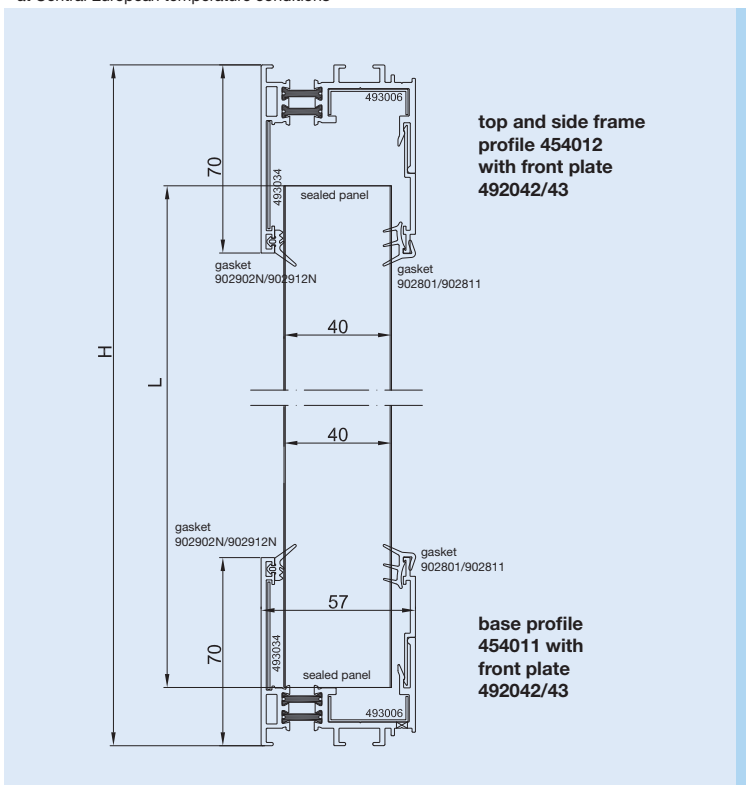

**Top profile 454012**  
**Base profile 454011**

**Article numbers**

**454012** = Top and side frame profile  
493006 = Profile connector for 454012  
493034 = Profile connector for 454012

**454011** = Base profile with drainage  
493006 = Profile connector for 454011  
493034 = Profile connector for 454011

**492042** = Front plate in L = 2.0 m  
**492043** = Front plate in L = 3.0 m

**902801** = Outer plug gasket TPE grey  
**902811** = Outer plug gasket TPE black

**902902N** = Inner lip gasket TPE grey  
**902912N** = Inner lip gasket TPE black

Calculation of panel length:  
 $L \text{ in mm} = \text{Height } H \text{ in mm} - 68 \text{ mm}$

### Facade 90° up to 12 m panel length\*

\* at Central European temperature conditions

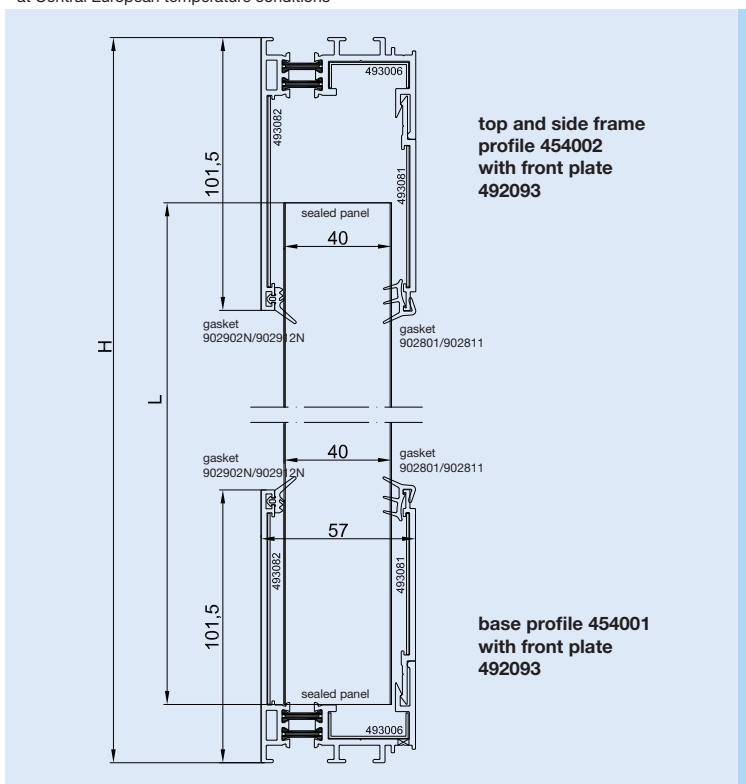

**Top profile 454002**  
**Base profile 454001**

**Article numbers**

**454002** = Top and side frame profile  
493082 = Profile connector for 454002  
493006 = Profile connector for 454002

**454001** = Base profile with drainage  
493082 = Profile connector for 454001  
493006 = Profile connector for 454001

**492093** = Front plate in L = 3.0 m  
493081 = Profile connector for 492093

**902801** = Outer plug gasket TPE grey  
**902811** = Outer plug gasket TPE black

**902902N** = Inner lip gasket TPE grey  
**902912N** = Inner lip gasket TPE black

Calculation of panel length:  
 $L \text{ in mm} = \text{Height } H \text{ in mm} - 75 \text{ mm}$

## 1.2.5.1

### Translucent Building Elements

Frame system thermally broken  
Top and base framing

Stand: 02/20

#### Facade 90° up to 6 m panel length\*

\* at Central European temperature conditions

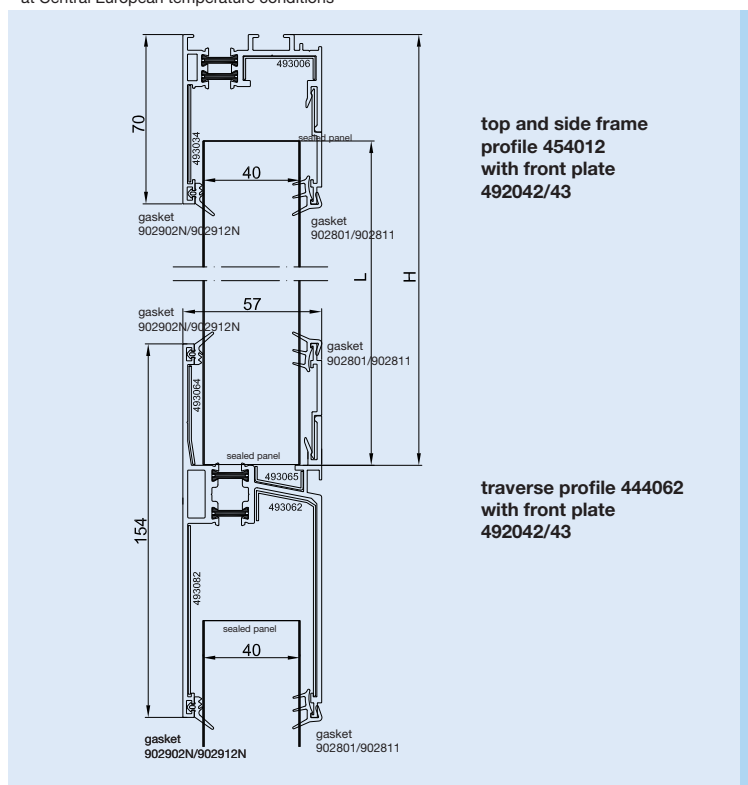

**Top profile 454012**  
**Traverse profile 444062**

#### Article numbers

**454012** = Top and side frame profile  
493006 = Profile connector for 454012  
493034 = Profile connector for 454012  
**492042** = Front plate in L = 2.0 m  
**492043** = Front plate in L = 3.0 m

**444062** = Traverse profile  
493062 = Profile connector for 444062  
493082 = Profile connector for 444062  
493064 = Profile connector for 444062  
493065 = Profile connector for 444062  
**492042** = Front plate in L = 2.0 m  
**492043** = Front plate in L = 3.0 m

**902801** = Outer plug gasket TPE grey  
**902811** = Outer plug gasket TPE black

**902902N** = Inner lip gasket TPE grey  
**902912N** = Inner lip gasket TPE black

Calculation of panel length:

$L$  in mm = Height  $H$  in mm - 45 mm

#### Facade 90° up to 12 m panel length\*

\* at Central European temperature conditions

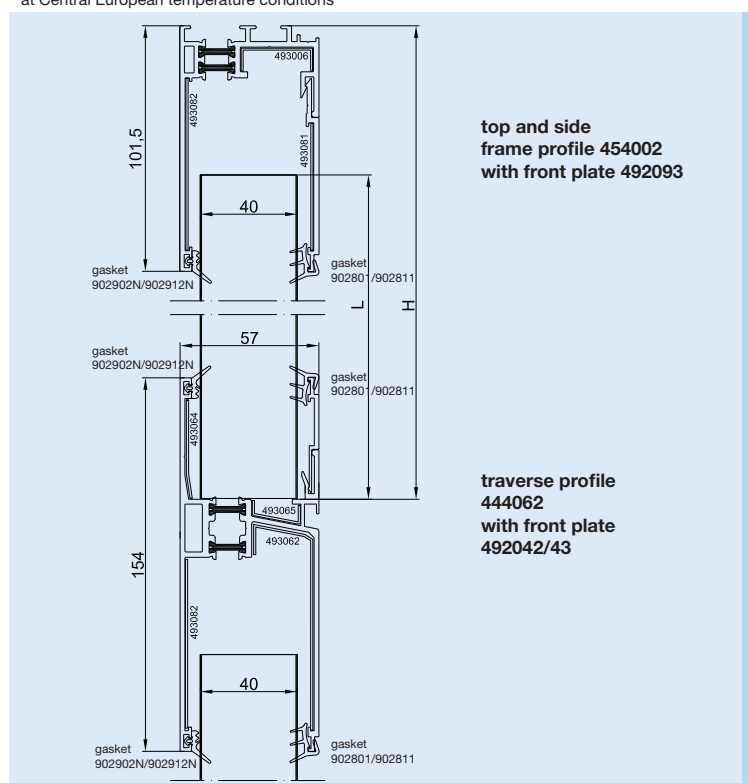

**Top profile 454002**  
**Traverse profile 444062**

#### Article numbers

**454002** = Top and side frame profile  
493082 = Profile connector for 454002  
493006 = Profile connector for 454002  
**492093** = Front plate in L = 3.0 m  
493081 = Profile connector for 492093

**444062** = Traverse profile  
493062 = Profile connector for 444062  
493082 = Profile connector for 444062  
493064 = Profile connector for 444062  
493065 = Profile connector for 444062  
**492042** = Front plate in L = 2.0 m  
**492043** = Front plate in L = 3.0 m

**902801** = Outer plug gasket TPE grey  
**902811** = Outer plug gasket TPE black

**902902N** = Inner lip gasket TPE grey  
**902912N** = Inner lip gasket TPE black

Calculation of panel length:

$L$  in mm = Height  $H$  in mm - 55 mm



## 1.2.5.2

### Translucent Building Elements

Frame system thermally broken  
Top and base framing

Facade 90° up to 12 m panel length\*

\* at Central European temperature conditions

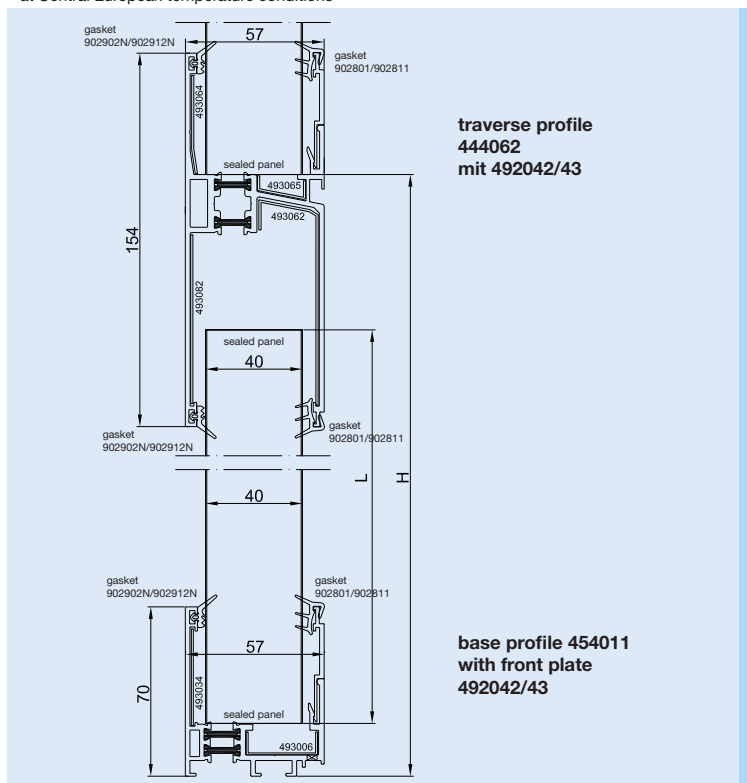

**Traverse profile** 444062  
**Base profile** 454011

#### Article numbers

**444062** = Traverse profile  
493062 = Profile connector for 444062  
493082 = Profile connector for 444062  
493064 = Profile connector for 444062  
493065 = Profile connector for 444062  
**492042** = Front plate in L = 2.0 m  
**492043** = Front plate in L = 3.0 m

**454011** = Base profile with drainage  
493006 = Profile connector for 454011  
493034 = Profile connector for 454011  
**492042** = Front plate in L = 2.0 m  
**492043** = Front plate in L = 3.0 m

**902801** = Outer plug gasket TPE grey  
**902811** = Outer plug gasket TPE black

**902902N** = Inner lip gasket TPE grey  
**902912N** = Inner lip gasket TPE black

Calculation of panel length:

$L$  in mm = Height  $H$  in mm - 80 mm

Facade 90° up to 12 m panel length\*

\* at Central European temperature conditions

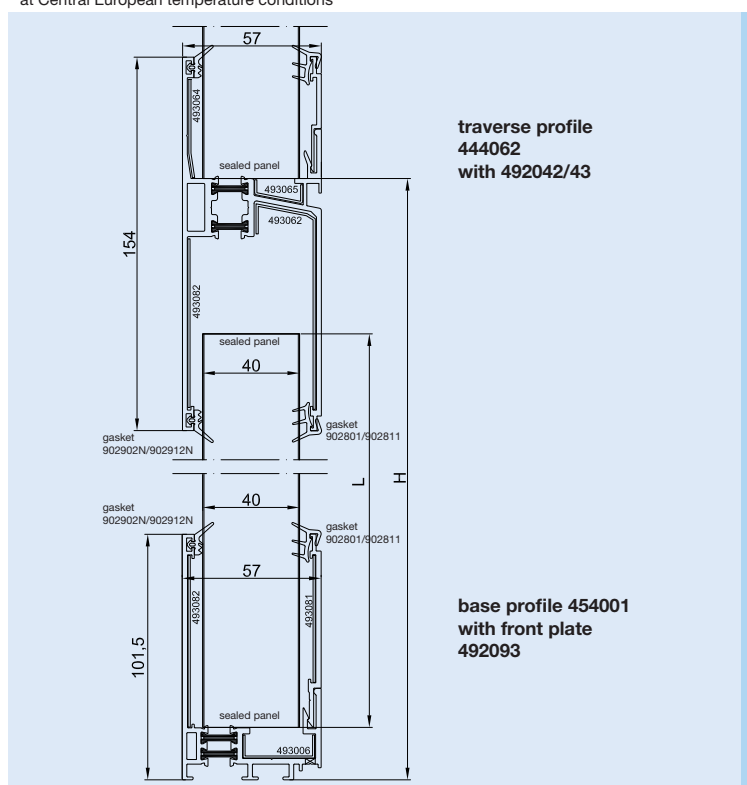

**Traverse profile** 444062  
**Base profile** 454001

#### Article numbers

**444062** = Traverse profile  
493062 = Profile connector for 444062  
493082 = Profile connector for 444062  
493064 = Profile connector for 444062  
493065 = Profile connector for 444062  
**492042** = Front plate in L = 2.0 m  
**492043** = Front plate in L = 3.0 m

**454001** = Base profile with drainage  
493082 = Profile connector for 454001  
493006 = Profile connector for 454001  
**492093** = Front plate in L = 3.0 m  
493081 = Profile connector for 492093

**902801** = Outer plug gasket TPE grey  
**902811** = Outer plug gasket TPE black

**902902N** = Inner lip gasket TPE grey  
**902912N** = Inner lip gasket TPE black

Calculation of panel length:

$L$  in mm = Height  $H$  in mm - 80 mm

## 1.2.5.3

### Translucent Building Elements

Frame system thermally broken  
Top and base framing

Stand: 02/20

#### Facade 90° up to 12 m panel length\*

\* at Central European temperature conditions

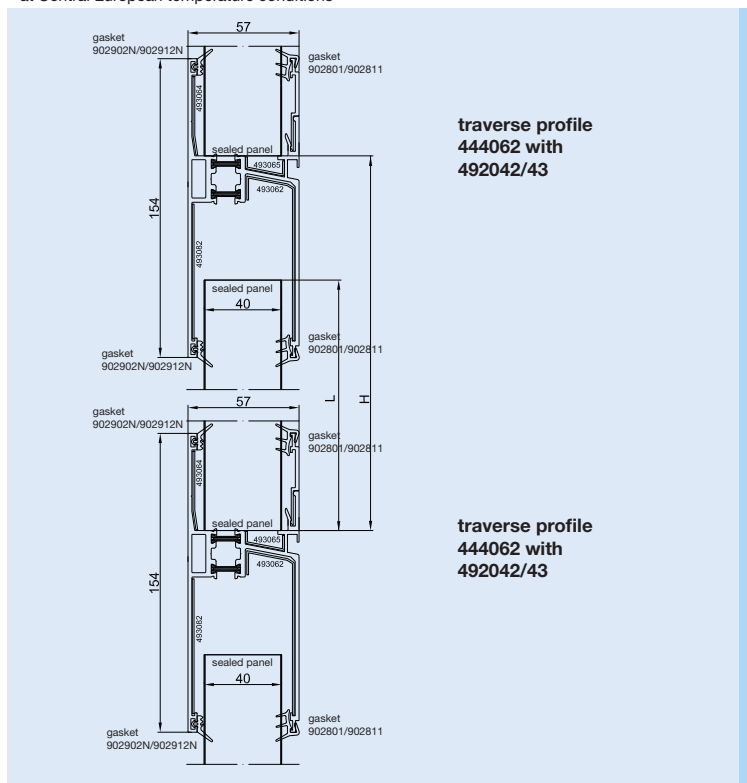

**Traverse profile 444062**  
**Traverse profile 444062**

#### Article numbers

**444062** = Traverse profile  
**493062** = Profile connector for 444062  
**493082** = Profile connector for 444062  
**493064** = Profile connector for 444062  
**493065** = Profile connector for 444062

**492042** = Front plate in L = 2.0 m  
**492043** = Front plate in L = 3.0 m

**902801** = Outer plug gasket TPE grey  
**902811** = Outer plug gasket TPE black

**902902N** = Inner lip gasket TPE grey  
**902912N** = Inner lip gasket TPE black

Calculation of panel length:

$L \text{ in mm} = \text{Height H in mm} - 60 \text{ mm}$

#### Vertical splitting of facade

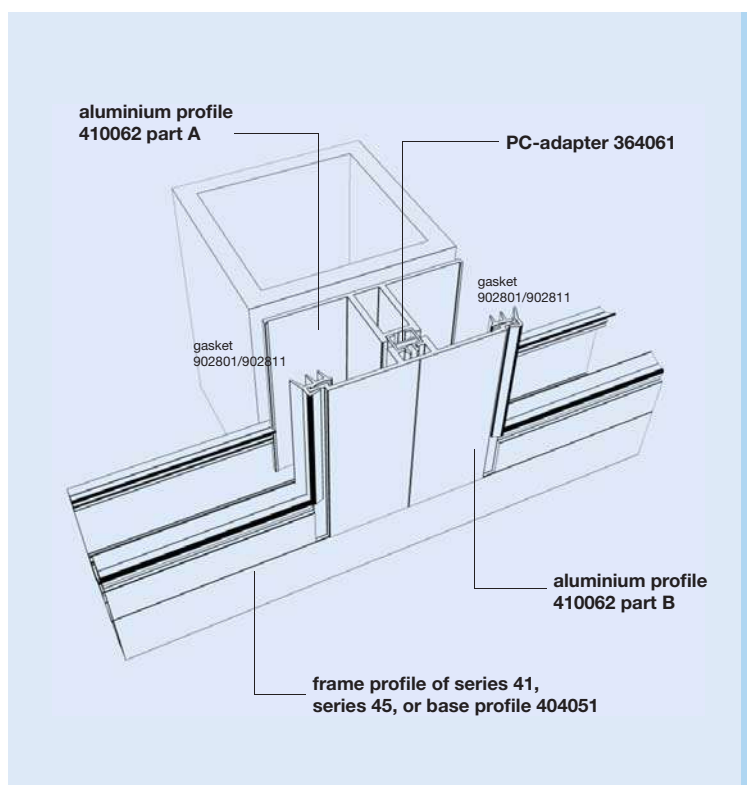

#### Vertical aluminium profile 410062

#### Article numbers

**410062 part A** = Aluminium bar  
**410062 part B** = Aluminium front profile

**364061** = PC-Adapter in L = 6.0 m

**902801** = Outer plug gasket TPE grey  
**902811** = Outer plug gasket TPE black

## 1.2.5.4

### Translucent Building Elements

Frame system thermally broken  
Top and base framing

Pitched installation  $>15^\circ$  up to 6 m panel length\*

\* at Central European temperature conditions

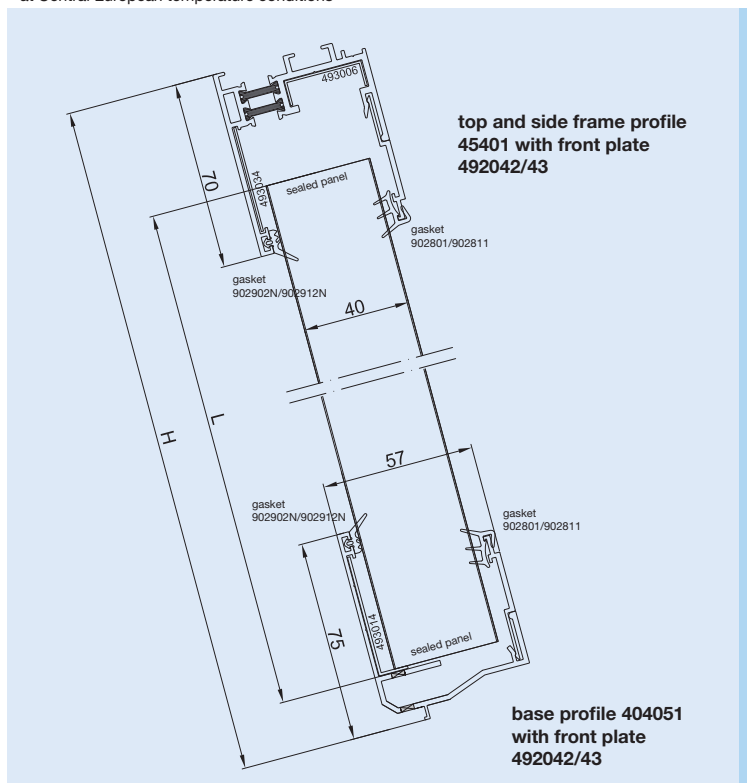

**Top profile** 454012  
**Base profile** 404051

#### Article numbers

**454012** = Top and side frame profile  
493006 = Profile connector for 454012  
493034 = Profile connector for 454012  
**492042** = Front plate in L = 2.0 m  
**492043** = Front plate in L = 3.0 m

**404051** = Base profile  
493014 = Profile connector for 404051  
**492042** = Front plate in L = 2.0 m  
**492043** = Front plate in L = 3.0 m

**902801** = Outer plug gasket TPE grey  
**902811** = Outer plug gasket TPE black

**902902N** = Inner lip gasket TPE grey  
**902912N** = Inner lip gasket TPE black

Calculation of panel length:

$L$  in mm = Height  $H$  in mm - 65 mm

Pitched installation  $>15^\circ$  up to 12 m panel length\*

\* at Central European temperature conditions

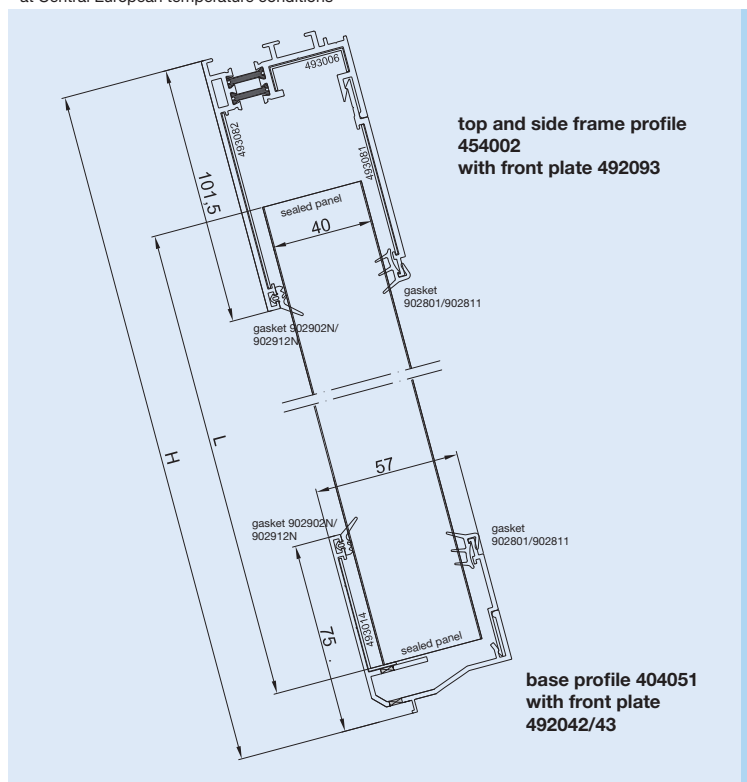

**Top profile** 454002  
**Base profile** 404051

#### Article numbers

**454002** = Top and side frame profile  
493082 = Profile connector for 454002  
493006 = Profile connector for 454002

**492093** = Front plate in L = 3.0 m  
493081 = Profile connector for 492093

**404051** = Base profile  
493014 = Profile connector for 404051

**492042** = Front plate in L = 2.0 m  
**492043** = Front plate in L = 3.0 m

**902801** = Outer plug gasket TPE grey  
**902811** = Outer plug gasket TPE black

**902902N** = Inner lip gasket TPE grey  
**902912N** = Inner lip gasket TPE black

Calculation of panel length:

$L$  in mm = Height  $H$  in mm - 75 mm



## 1.2.5.5

### Translucent Building Elements

Frame system thermally broken  
Corner connection

Stand: 02/20

#### 90° corner connection 454005

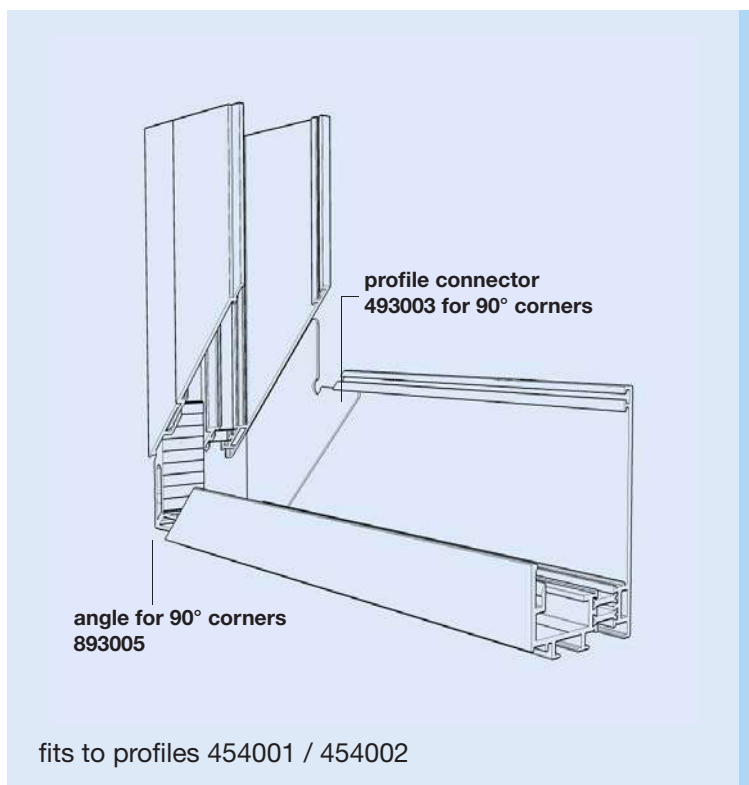

#### General

90° corner connections of the profiles 454002 and 454012 are available as prefabricated components.

The corner connections are made of 0.55 m long frame profiles, incl. front plates. The connections are sealed with profile connectors and sealant and thus save installation time and effort.

#### Initial lengths/-units

Prefabricated corner profile incl. front plates and profile connectors	1 pc. PU*
Length 0.55 m	
Profile connector 493003	4 pcs. PU*
Angle for 90° corner 893005	4 pcs. PU*
TPE gaskets, grey or black or special colour on request	50 m rolls
Profile connector	10 cm

\*PU = Packing unit

#### 90° corner connection 454015

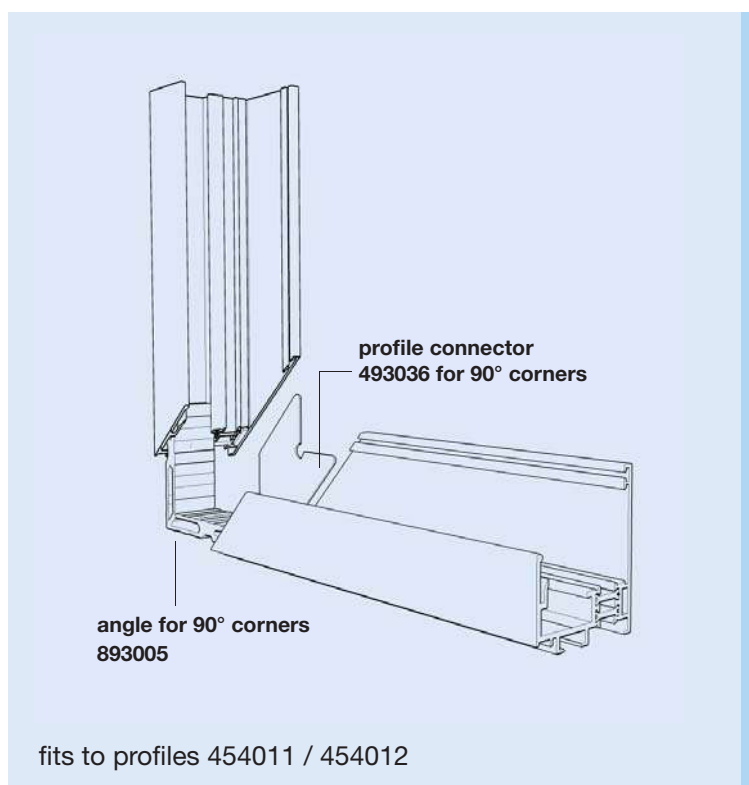

#### Article numbers

**454005** = 90° corner connection prefabricated  
incl. profile connectors and front plate,  
fits to profile 454001 & 454002

493003 = profile connector for a 90° corner  
of profile 454001/02

893005 = angle for a 90° corner of profile 454001/02

**454015** = 90° corner connection prefabricated  
incl. profile connectors and front plate,  
fits to profile 454011 & 454012

493036 = profile connector for a 90° corner  
of profile 454011/12

893005 = angle for a 90° corner of profile  
454011/12

#### Versions

Aluminium - mill finish

Aluminium - anodized E6/C0

Aluminium - powder coated according to RAL

## 1.2.5.6

### Translucent Building Elements

Frame system thermally broken  
Lateral framing

#### Side connection

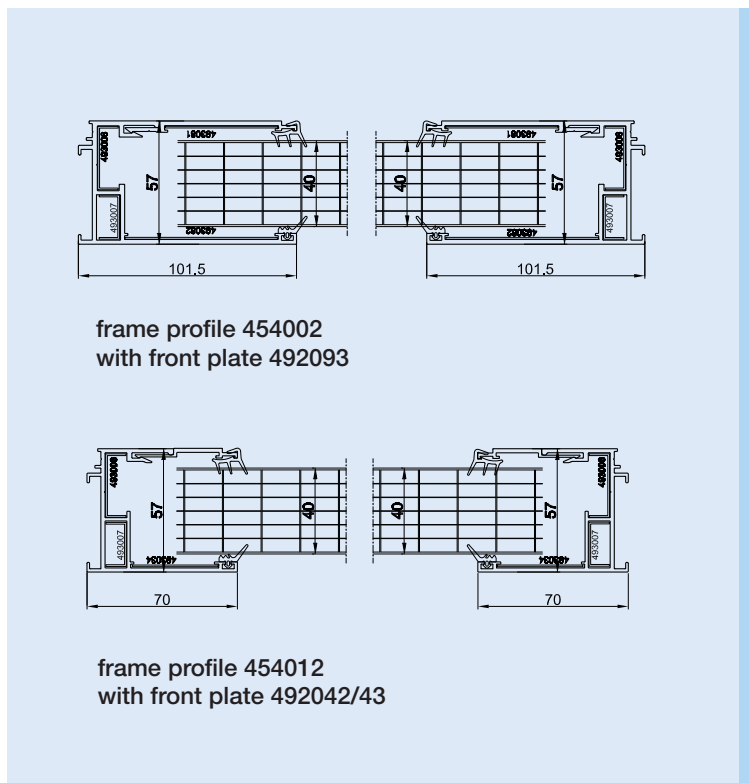

#### Side connection with frame profiles

##### Article numbers

**454012** = Top and side frame profile  
**493006** = Profile connector for 454012  
**493034** = Profile connector for 454012  
**492042** = Front plate in L = 2.0 m  
**492043** = Front plate in L = 3.0 m

**454002** = Top and side frame profile  
**493082** = Profile connector for 454002  
**493006** = Profile connector for 454002  
**492093** = Front plate in L = 3.0 m  
**493081** = Profile connector for 492093

**902801** = Outer plug gasket TPE grey  
**902811** = Outer plug gasket TPE black

**902902N** = Inner lip gasket TPE grey  
**902912N** = Inner lip gasket TPE black

#### Side connection 90° corner

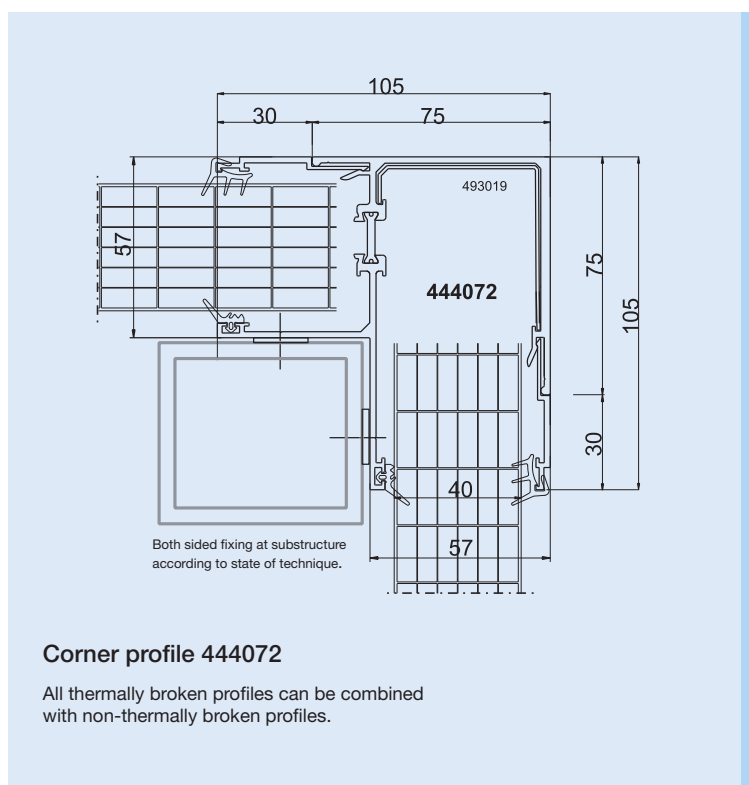

#### Side connection 90° corner with profile 444072

##### Article numbers

**444072** = Corner profile  
**493019** = Profile connector for 444072

**492042** = Front plate in L = 2.0 m  
**492043** = Front plate in L = 3.0 m

**902801** = Outer plug gasket TPE grey  
**902811** = Outer plug gasket TPE black

**902902N** = Inner lip gasket TPE grey  
**902912N** = Inner lip gasket TPE black

# 1.2.6.0

## Translucent Building Elements

Frame system Eco non-thermally broken  
Top and base framing

Stand: 02/20

### Facade 90° up to 6 m panel length\*

\* at Central European temperature conditions

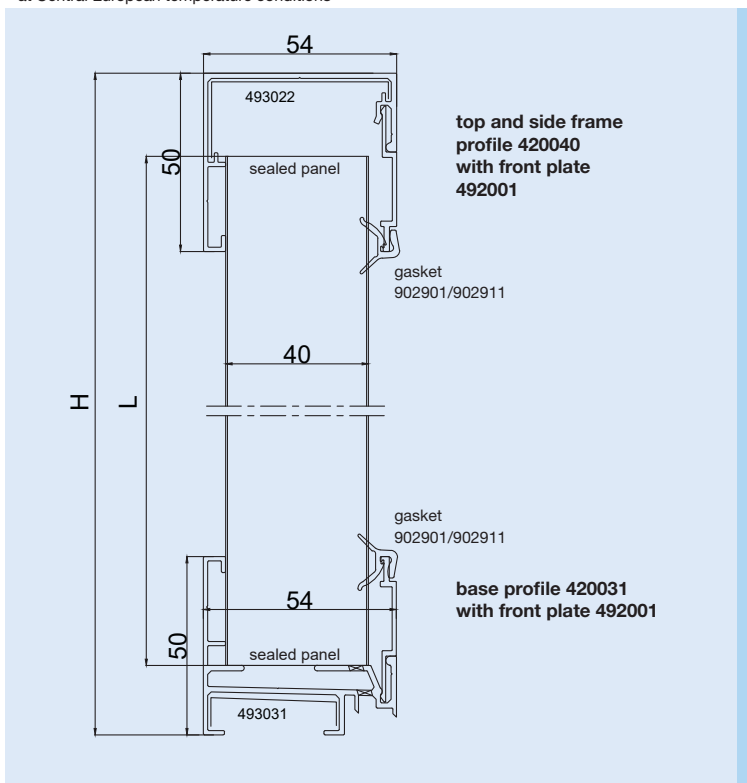

**Top profile 420040**  
**Base profile 420031**

#### Article numbers

**420040** = Top and side frame profile  
**493022** = Profile connector for 420040

**492001** = Front plate in L = 3.0 m

**420031** = Base profile  
**493031** = Profile connector for 420031

**492001** = Front plate in L = 3.0 m

**902901** = Outer plug gasket TPE grey  
**902911** = Outer plug gasket TPE black

Calculation of panel length:

$L$  in mm = Height  $H$  in mm - 40 mm

### Facade 90° up to 12 m panel length\*

\* at Central European temperature conditions

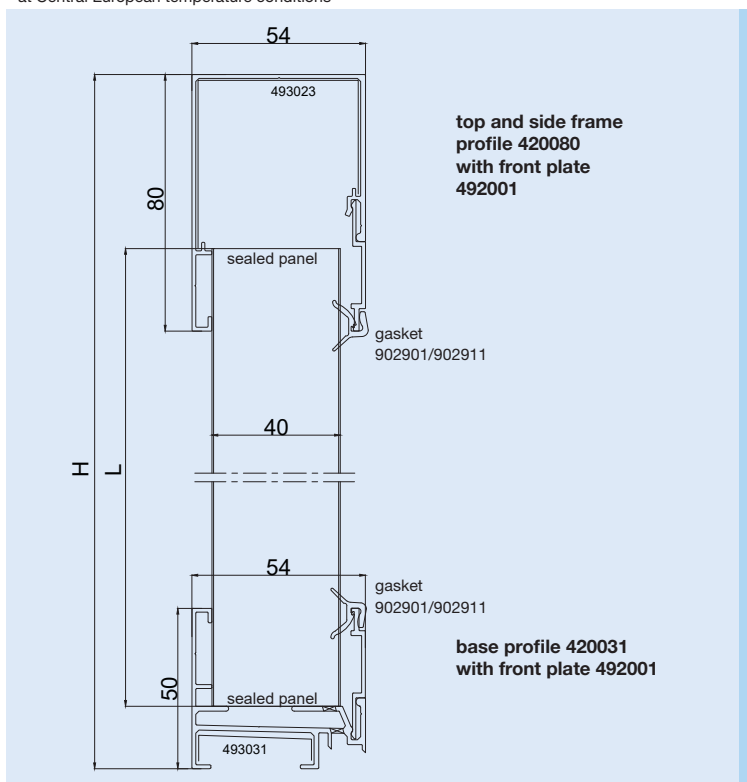

**Top profile 420080**  
**Base profile 420031**

#### Article numbers

**420080** = Top and side frame profile  
**493023** = Profile connector for 420080

**492001** = Front plate in L = 3.0 m

**420031** = Base profile  
**493031** = Profile connector for 420031

**492001** = Front plate in L = 3.0 m

**902901** = Outer plug gasket TPE grey  
**902911** = Outer plug gasket TPE black

Calculation of panel length:

$L$  in mm = Height  $H$  in mm - 60 mm



## 1.2.6.1

### Translucent Building Elements

Frame system Eco non-thermally broken  
Lateral framing

#### Side connection

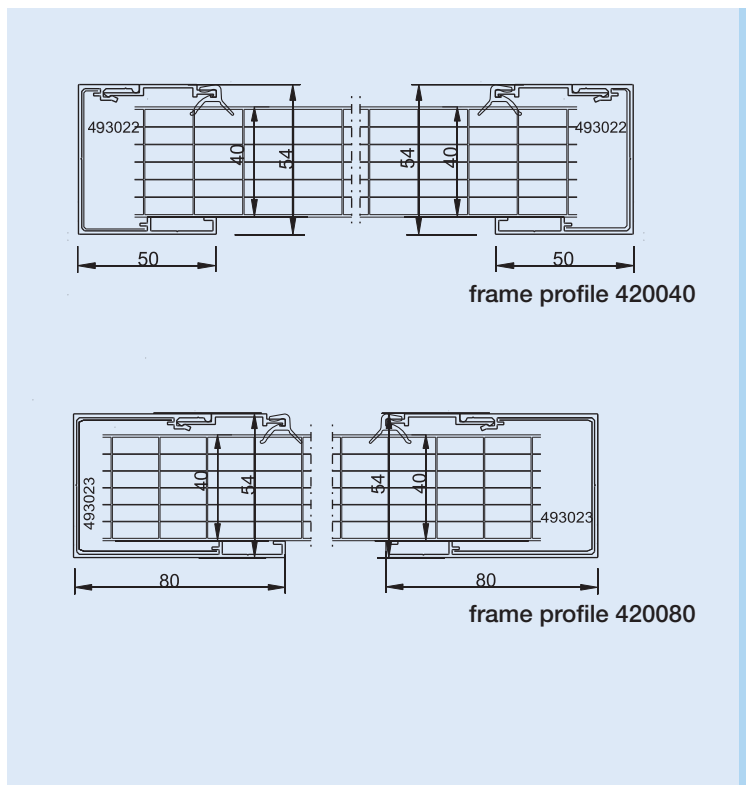

#### Side connection with frame profiles

##### Article numbers

**420040** = Top and side frame profile  
**493022** = Profile connector for 420040

**420080** = Top and side frame profile  
**493023** = Profile connector for 420080

**492001** = Front plate in L = 3.0 m

**902901** = Outer plug gasket TPE grey  
**902911** = Outer plug gasket TPE black

#### Side connection 90° corner

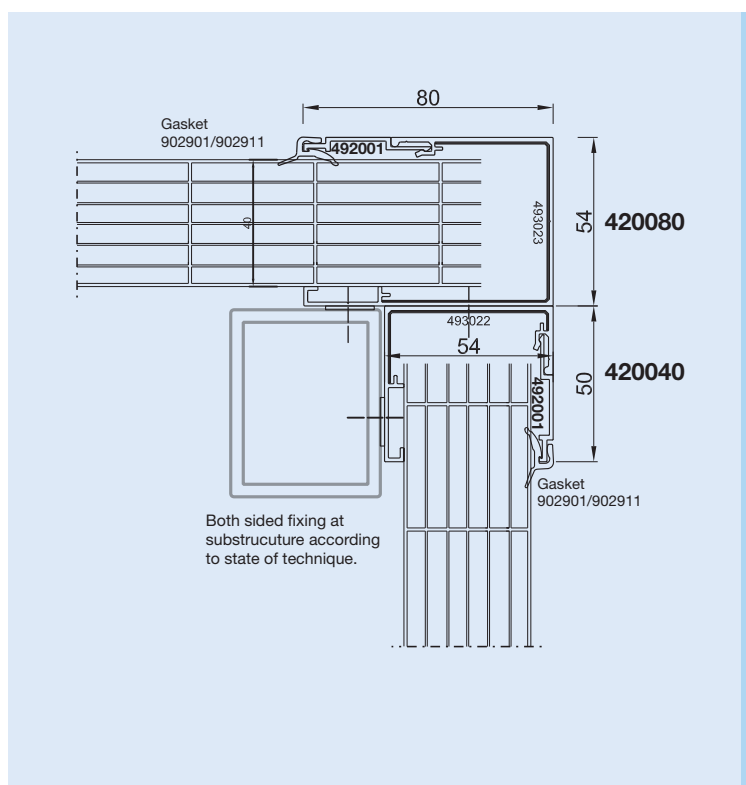

#### Side connection 90° corner with frame profile 420040 - 420080

##### Article numbers

**420040** = Top and side frame profile  
**493022** = Profile connector for 420040

**420080** = Top and side frame profile  
**493023** = Profile connector for 420080

**492001** = Front plate in L = 3.0 m

**902901** = Outer plug gasket TPE grey  
**902911** = Outer plug gasket TPE black

## 1.2.7.0

### Translucent Building Elements

#### Windowsills and accessories

Stand: 02/20

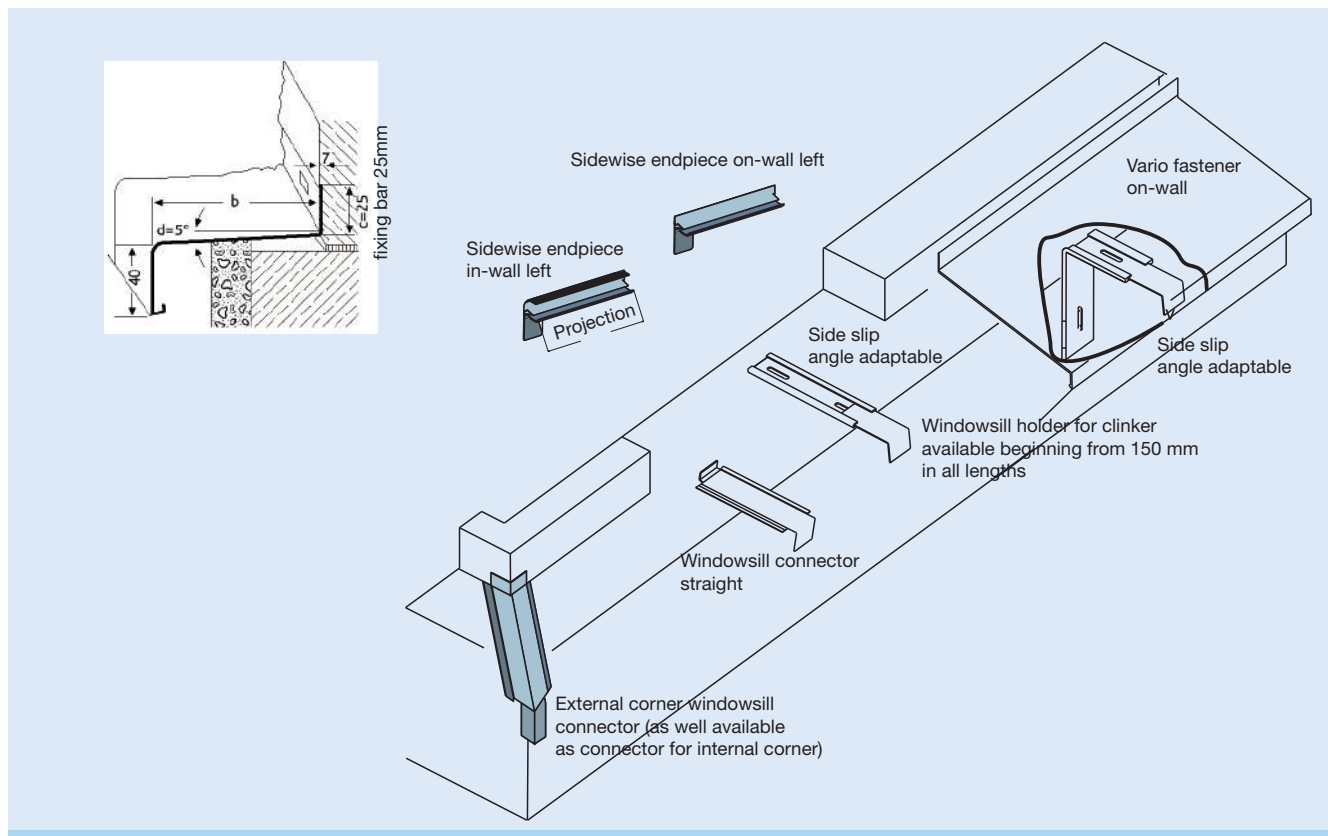

#### Installation manual - Windowsill products

##### Please note before installing:

- Thermal expansion of the profiles:  
Windowsills over 3,000 mm long must be divided in the middle and extended through a connection joint. The windowsills must be sufficiently fastened to the frame and be tight against rain water. The possibility for the windowsill to expand must be made sure depending on length.
- For sound insulation during heavy rains we recommend to provide windowsills with a sound absorptive stripe. The sound absorptive area should be around 1/3 of the windowsill area.
- Aluminium windowsills should project about 40 mm over the finished facade. The profile width should be measured accordingly. This applies only for installations with side endings. Without side endings the projection of windowsills should not be lower than 20mm.
- From a projection/profile depth of 150 mm holders (Vario fastener or clinker fastener) are necessarily to be used on the structure (every 800 to 1,000 mm).

##### Note for installation:

Before installation of the side elements stick the sound absorptive stripes approx. 50 mm behind the beginning of the drip edge on the bottom side of the windowsill profile.

Please don't forget to leave free approx. 30 mm on the front sides of the windowsill in order to be able to install the side elements.

On the predrilled (perforated) side of the windowsill insert the gasket, check the straight and precise seating of the rubber profile and remove the cover strip from the adhesive surface. (This does not apply to assemblies with Rodeca profiles)

Before screwing the windowsills, if using Rodeca profiles, the base profile and chosen adapter are installed to the supporting substructure. The side elements are to be clipped on in advance. After clipping on the side elements and fastening the windowsill, seal the connection points all around. Please leave at least 5 mm on each side of the windowsill for the thermal expansion.

If implementing full thermal protection it is important to make sure that the vario fastener is fixed before placing the insulation to the masonry. This also applies if using the holder for clinker installation.

The windowsill with the protective foil side at the top is to be fixed at the edge of the window using windowsill screws. The foil may not be covered while assembling the connector elements. Make sure to provide the final windowsill slope of at least 5° after the assembly. When plastering the side elements please check the presence of expansion joint and keep in mind the thermal expansion of aluminium. Coarse mortar and plaster remnants must be removed immediately from the protective foil. After completion of the facade work in the windowsill area, the protective foil has to be removed as quickly as possible.



# 1.2.7.1

## Translucent Building Elements

### Windowsills and accessories

Example for construction group:

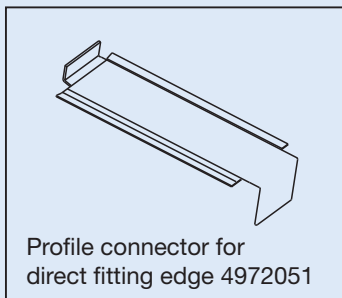
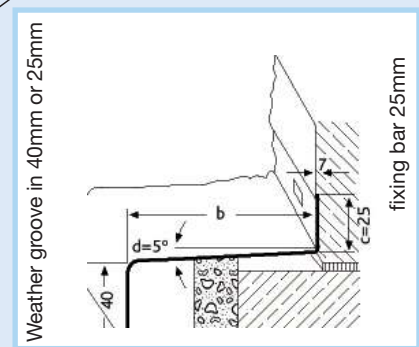
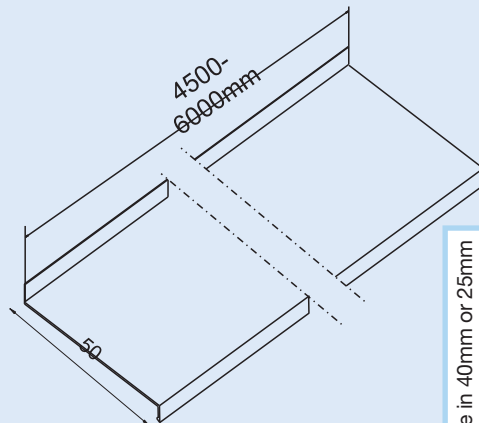
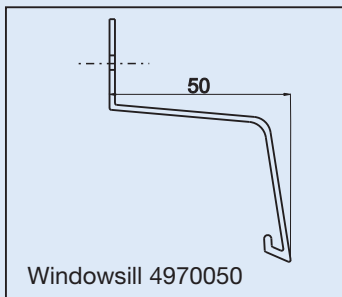

Windowsill projection

Example: article numbers for a 50 mm windowsill projection:

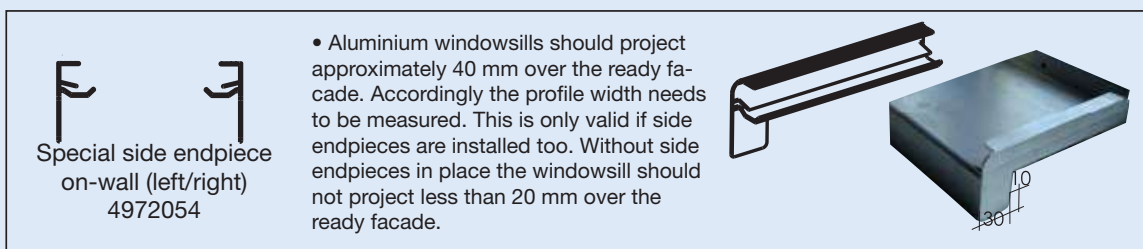
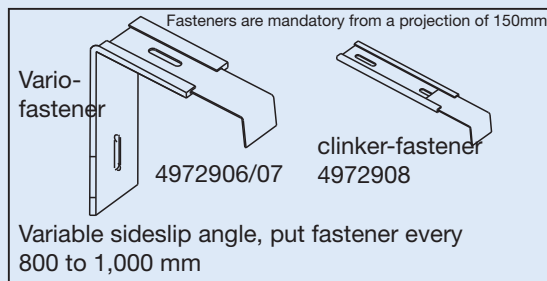
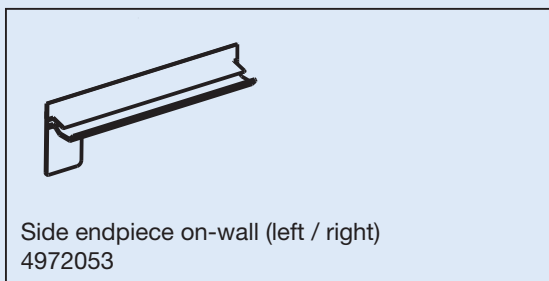
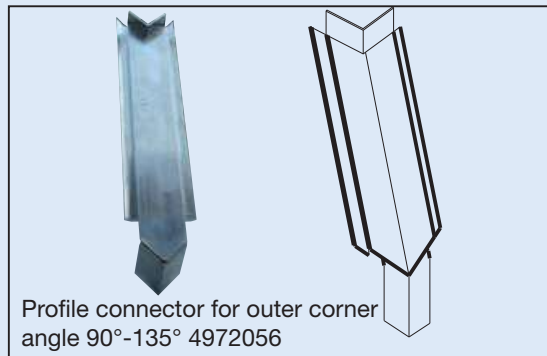
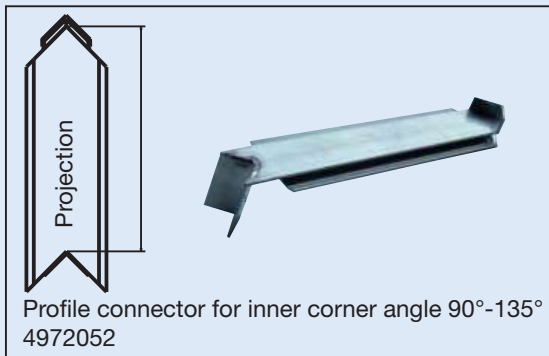

## 1.2.7.2

### Translucent Building Elements

Windowsills and accessories

Framing system non-thermally broken

Stand: 02/20

Aluminium windowsills for non-thermally broken frame profiles with adapter profiles

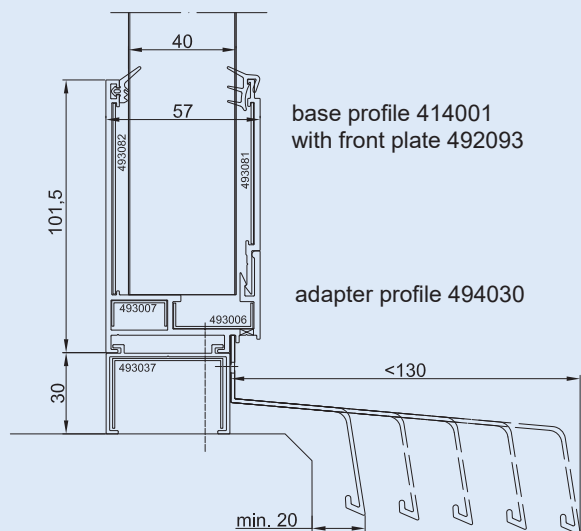

Base profile 414001 (also 414011) with adapter profile 494030 for windowsill projections from 50 mm to 130 mm.

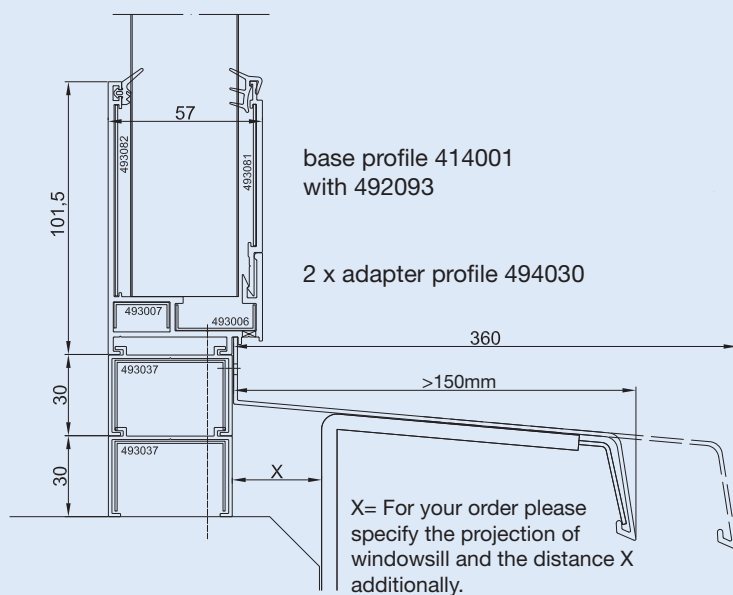

Base profile 414001 (also 414011) with 2 x adapter profile 494030 for windowsill projections from 150 to 360 mm.

#### General

Compatible to non-thermally broken frame profiles we offer suitable adapter profiles for connection of windowsills with varying projections.

#### Initial lengths/-units

Aluminium profile	6.00 m
Profile connector	10 cm

#### Article numbers

**4971070** = windowsill 70 mm projection  
**4971110** = windowsill 110 mm projection  
**4971150** = windowsill 150 mm projection

windowsills with 70mm / 110 mm / 150 mm projection available from stock

**494030** = adapter profile for profile 414001 and 414011  
**493037** = Profile connector for 494030

**For use with adapter profile 494030 the allowance for calculation of panel length must be increased by 30 mm per adapter profile.**

Aluminium windowsills should project approx. 40 mm over facade. This applies only if side end pieces are installed. Without side end pieces the windowsill must project 20 mm over facade.

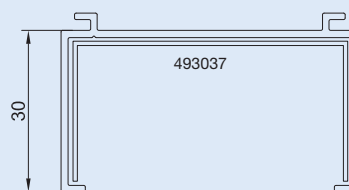

adapter profile 494030



# 1.2.7.3

## Translucent Building Elements

Windowsills and accessories

Framing system thermally broken

Aluminium windowsills for thermally broken frame profiles with adapter profiles

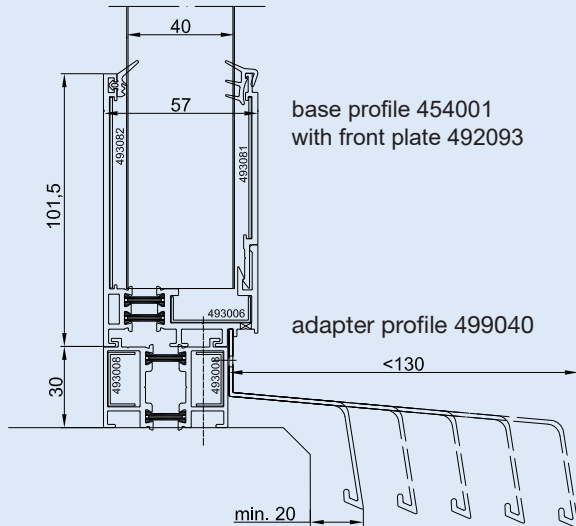

base profile 454001  
with front plate 492093

adapter profile 499040

Base profile 454001 (also 454011) with adapter profile 499040 for windowsill projections from 50 mm to 130 mm.

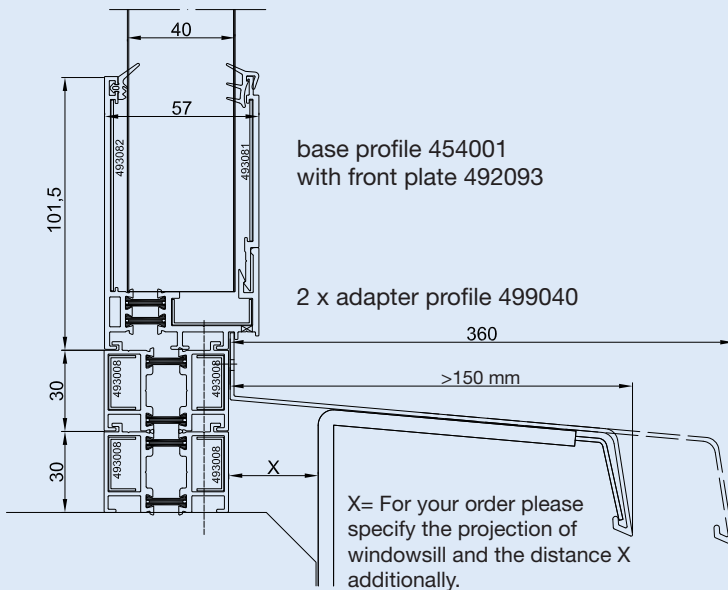

base profile 454001  
with front plate 492093

2 x adapter profile 499040

X= For your order please  
specify the projection of  
windowsill and the distance X  
additionally.

Base profile 454001 (also 454011) with 2 x adapter 499040 for windowsill projections from 150 to 360 mm.

### General

Compatible to thermally broken frame profiles we offer suitable thermally broken adapter profiles for connection of windowsills with varying projections.

### Initial lengths/-units

Aluminium profile	6.00 m
Profile connector	10 cm

### Article numbers

4971070 = Windowsill 70 mm projection  
4971110 = Windowsill 110 mm projection  
4971150 = Windowsill 150 mm projection

Windowsills with 70mm / 110 mm / 150 mm projection available from stock

499040 = Thermally broken adapter profile for 454001/454011

493008 = Profile connector for 499040

**For use with adapter profile 499040 the allowance for calculation of panel length must be increased by 30 mm per adapter profile.**

Aluminium windowsills should project approx. 40 mm over facade. This applies only if side end pieces are installed. Without side end pieces the windowsill must project 20 mm over facade.

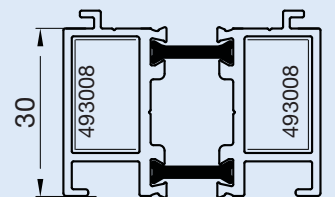

adapter profile 499040



# 1.2.7.4

## Translucent Building Elements

Windowsills and accessories

Framing system ECO non-thermally broken

Stand: 02/20

Aluminium windowsills for non-thermally broken Eco frame profiles with adapter profiles

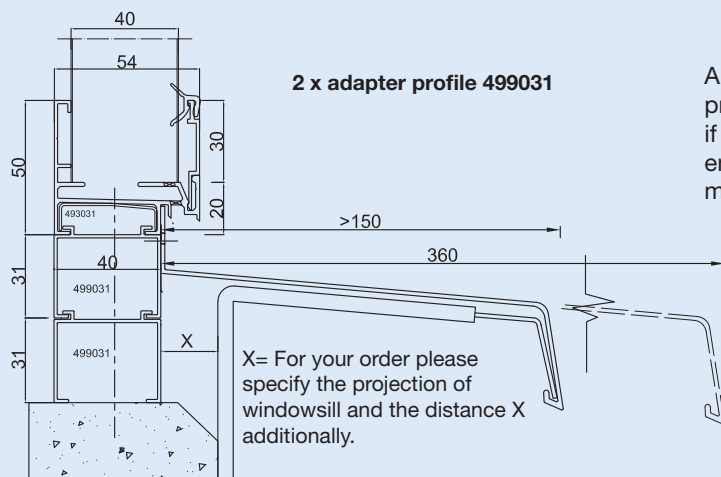
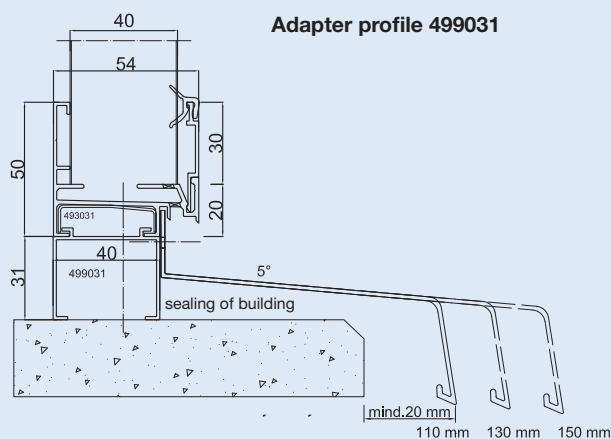
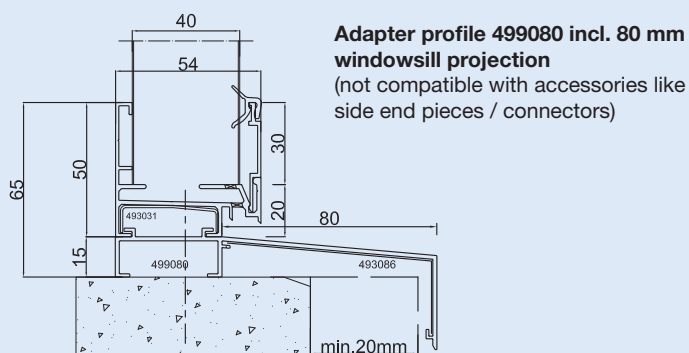

### General

Compatible to non-thermally broken frame profiles we offer suitable adapter profiles for connection of windowsills with varying projections.

### Initial lengths/-units

Aluminium profile	6.00 m
Profile connector	10 cm

### Article numbers

- 4971070 = Windowsill 70 mm projection
- 4971110 = Windowsill 110 mm projection
- 4971150 = Windowsill 150 mm projection

Windowsills with 70 mm / 110 mm / 150 mm projection available from stock

- 499080 = Adapter profile for profile 420031 incl. windowsill with 80 mm projection
- 493086 = Profile connector for 499080

- 499031 = Adapter profile for profile 420031

For use with adapter profile incl. windowsill 499080 the allowance for calculation of panel length must be increased by 15 mm per adapter profile.

For use with adapter profile 499031 the allowance for calculation of panel length must be increased by 31 mm per adapter profile.

Aluminium windowsills should project approx. 40 mm over facade. This applies only if side end pieces are installed. Without side end pieces the windowsill must project 20 mm over facade.



## Windows

### Opening systems for Rodeca-facades

#### Manufacturing program

Details and sizes of the windows can be seen in the technical manual for windows: <https://www.rodeca.de/de/downloads>

#### Series 80

non-thermally broken aluminium window

The glazing is possible with 40 mm panels respectively with isolation glass up to 20 mm

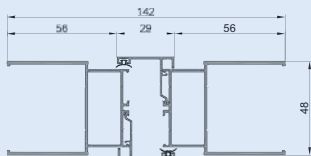

#### Series 85

thermally broken aluminium window system

The glazing is possible with 40/50/60 mm panels depending on the type of opening respectively with isolation glass up to 48 mm

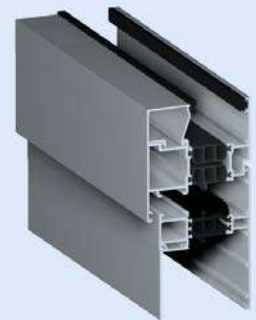
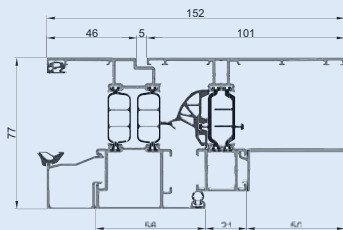

#### Series 86

thermally broken aluminium window system

The glazing is possible with 40/50/60 mm panels

